

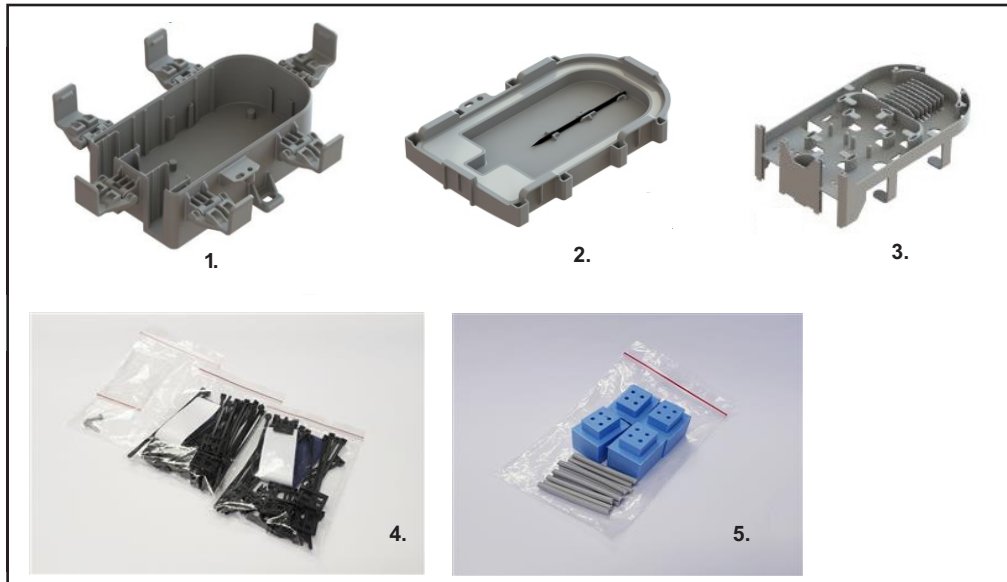

# COYOTE® STP-MD

Be sure to read and completely understand this procedure before applying product. Be sure to select the proper PREFORMED™ product before application.



### NOMENCLATURE

1. Base (1) + Latches (6)
2. Cover (1) + Fiber pick (1)
3. Splice Platform (1)
4. Retention clips, Silicone lubricant, Mounting bracket, Self-Tapping screws (1 kit)
5. Grommet Kit (1)

### TOOLS REQUIRED

- Fiber optic cable opening tools
- Phillips Screwdriver
- Snips

**Step #1** Measure the diameter of each cable to make sure that it will be able to be used in the grommets provided with the closure.

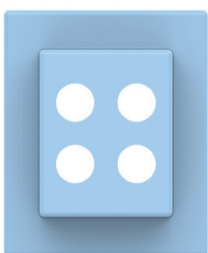
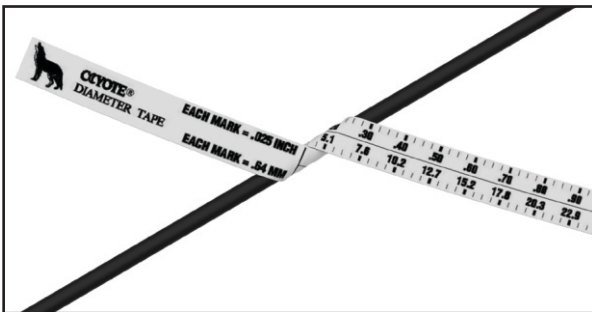

Ensure you have selected the correct grommet size that matches your cable.

**Step #2** Install a plug into any unused hole of each grommet.

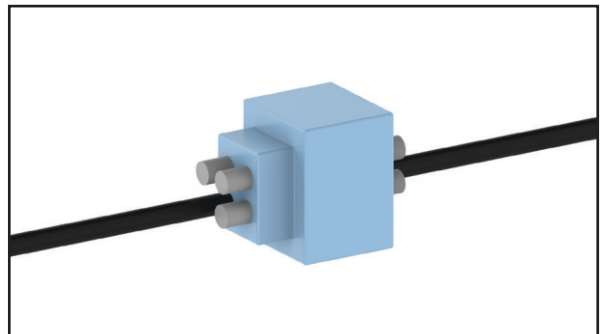

### Preparation of Round Drop Cable

**Step #3** Measure, mark, and remove the cable sheath for cut cables as shown below.

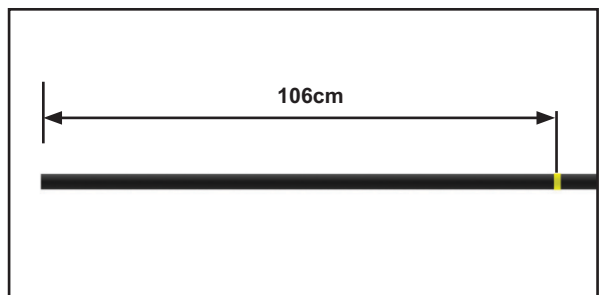

**Step #4** Remove the buffer tube at a minimum of 6mm & a maximum of 500mm away from sheath opening.

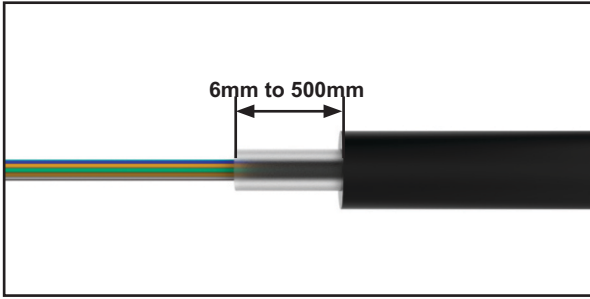

**Step #5** Adjust the cable so that the sheath opening is positioned 19mm from the grommet.

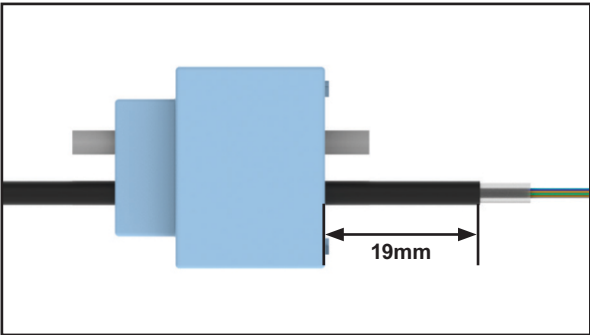

**Step #6** Align the grommets with the splice platform. Insert the cable retention clips into the slots of the platform & push down on them until they are completely installed into the slots. See **STP retention clip application instructions**, for cable retention instructions.

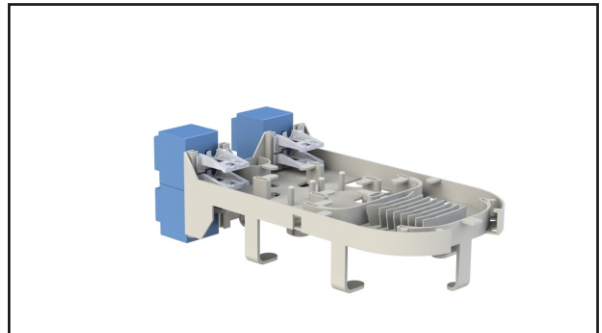
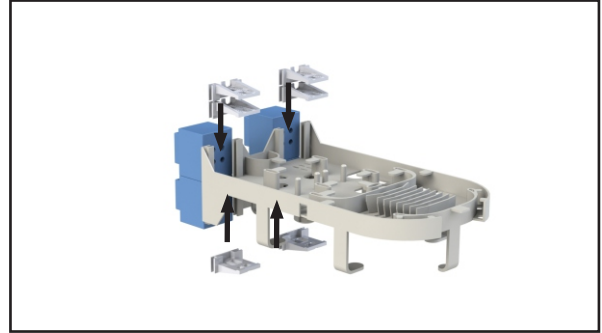

### Buffer tube Routing in the Splice Platform

**Step #7** Route the buffer tube

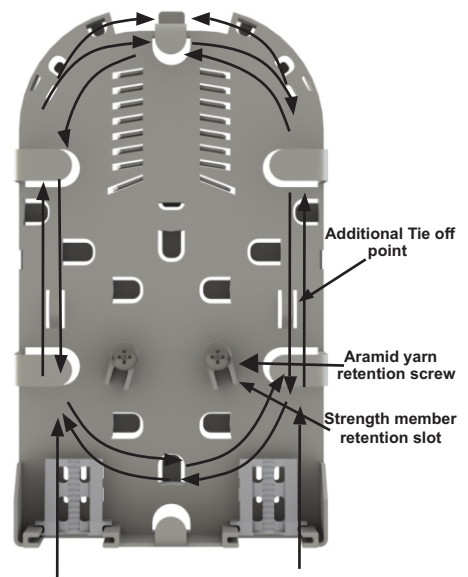

**Fiber Routing in the Splice Platform  
(Straight Splice Applications)**

**Step #8** Route the incoming fibers.

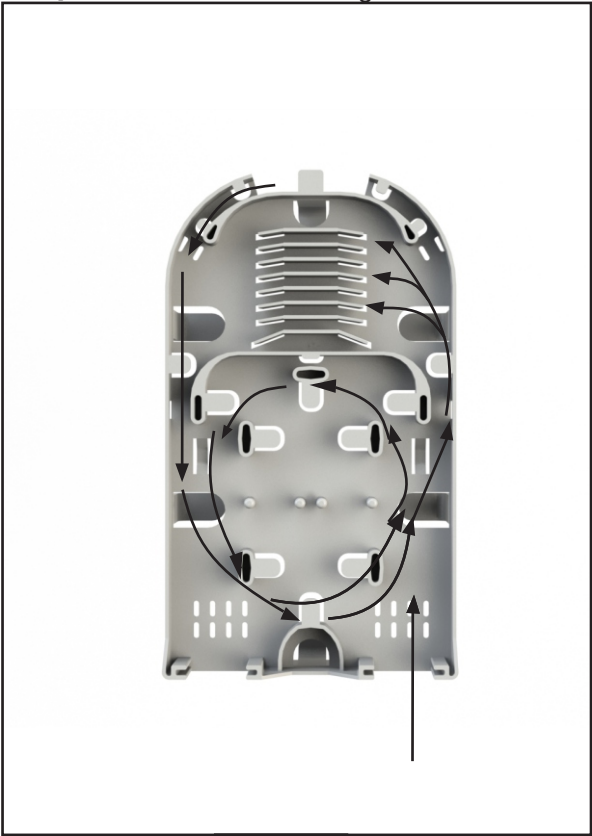

**OR**



**Step #9** Route the outgoing fibers.

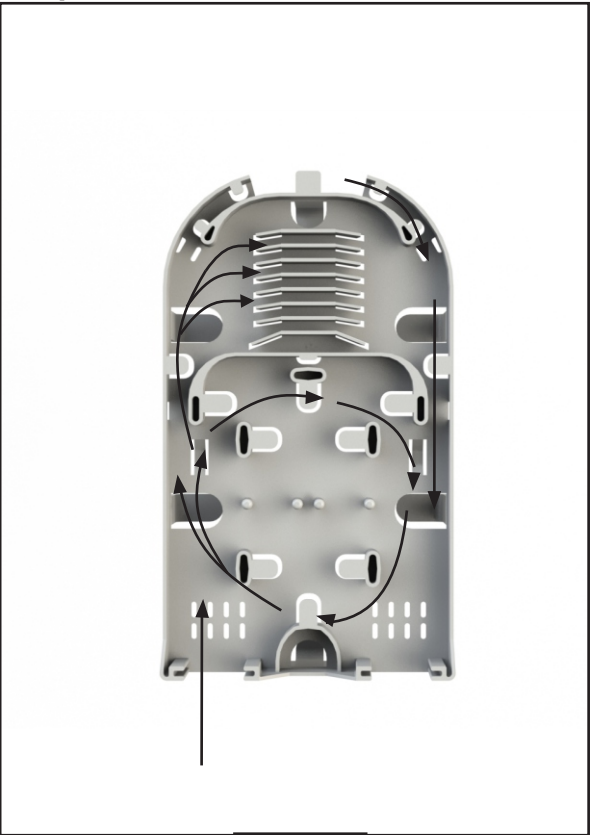

**OR**

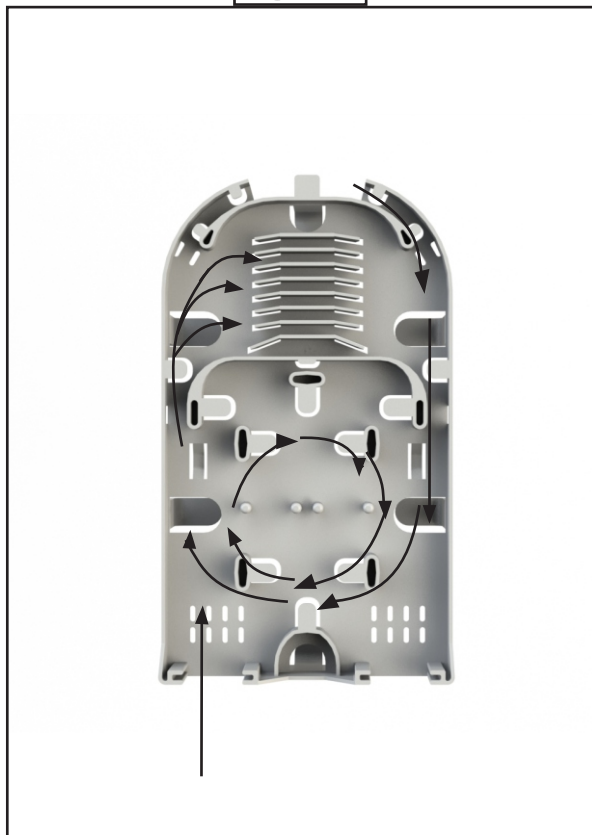

**Step #10** Splice the incoming fibers to the outgoing fibers per your accepted company practise. (Skip to step 19)

**Fiber routing in the splice platform  
(Cross-Connect Applications)**

**Step #11** Route the incoming fibers.

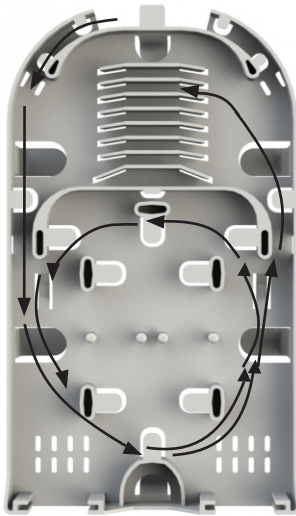

**OR**

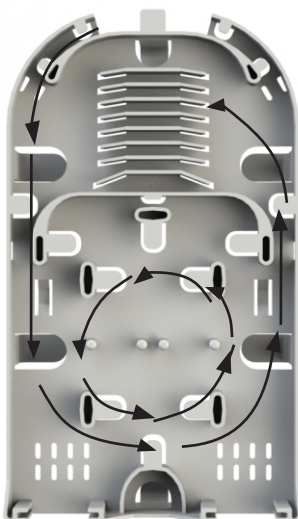

**Step #12** Route the outgoing fibers.

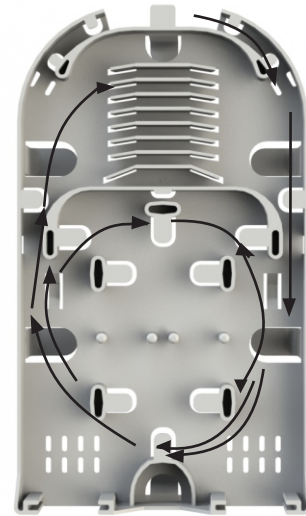

**OR**



**NOTE:** If needed, a fiber pick is included to help maneuver the fibers into the routing channels of the platform.

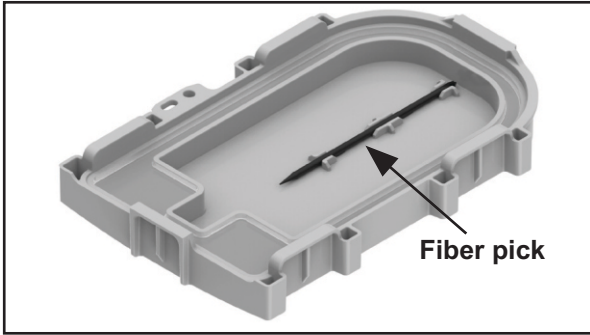

### Preparation and Routing of Pigtails for Cross-Connect Applications

**Step #13** Measure and mark the jacket of the pigtails as shown below. Remove the jacket of each pigtail beyond the marked location.

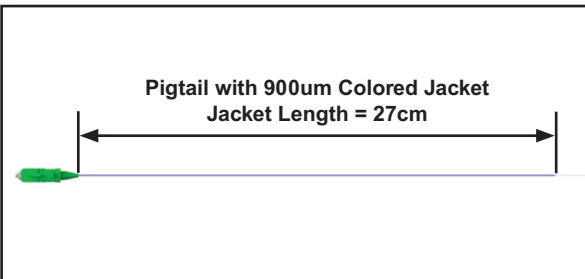

**Step #14** Splice the incoming fiber(s) to the incoming pigtail(s) and the outgoing fiber(s) to the outgoing pigtail(s) per your accepted company practice.

### Step #15 Route the incoming pigtails

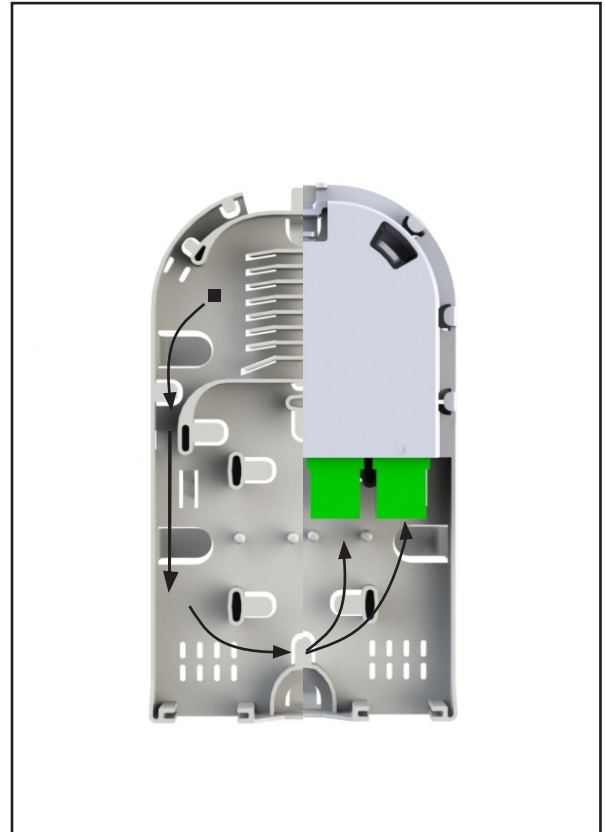

**OR**

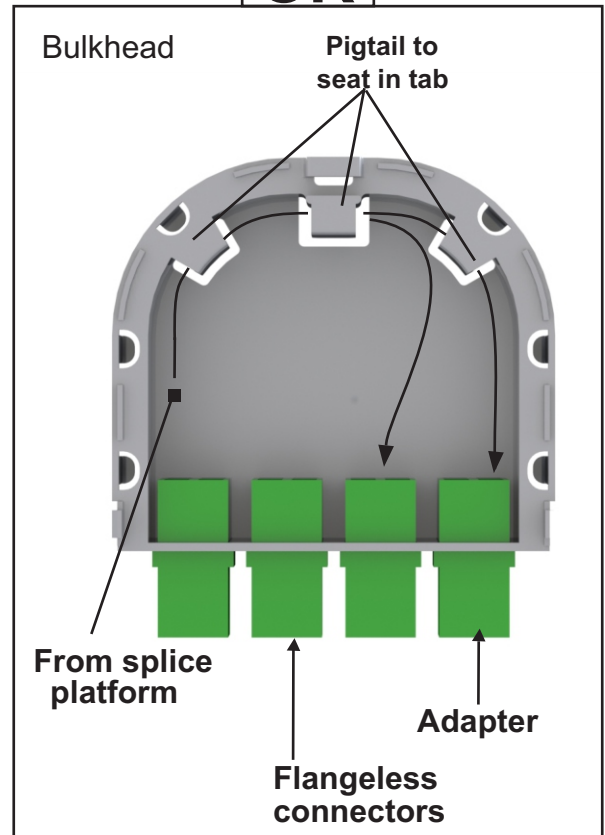

**Step #16** Route the outgoing pigtails

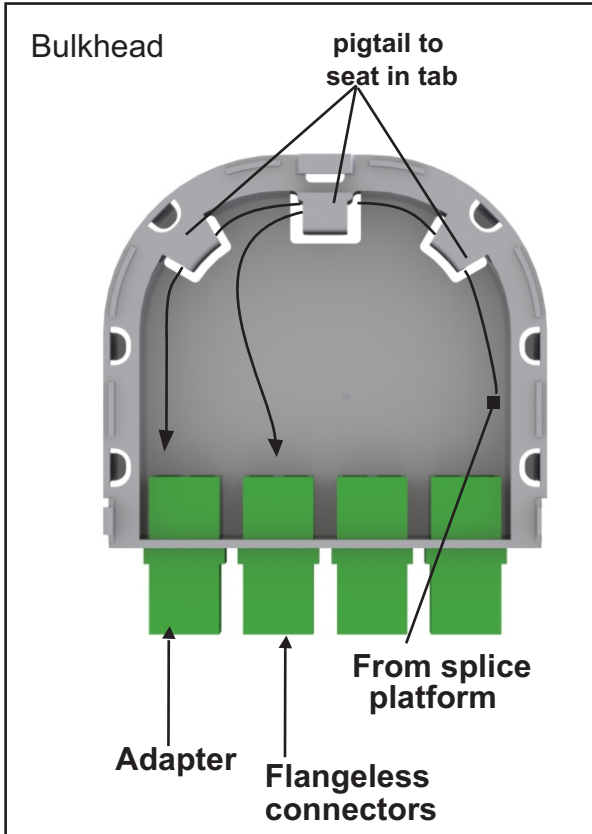

**Step #17** Install the adapters in the bulkhead bracket.

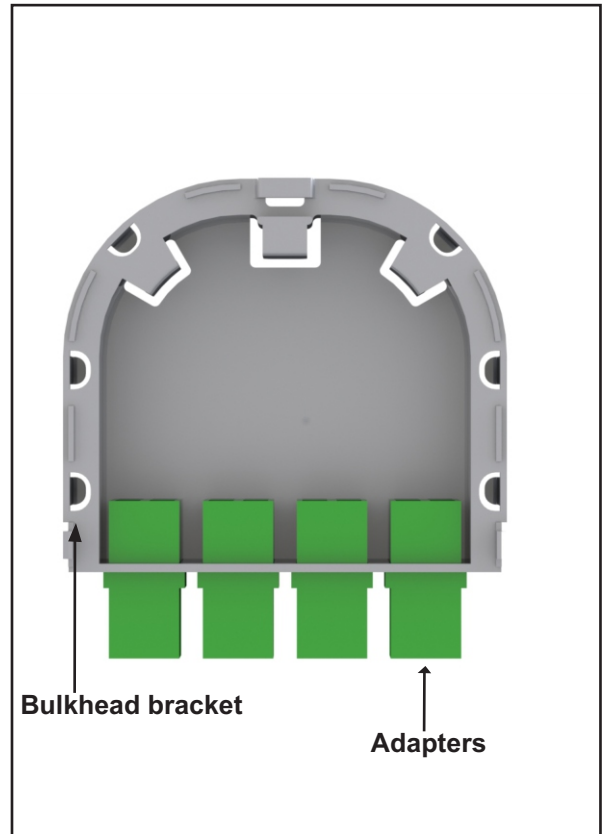

**OR**

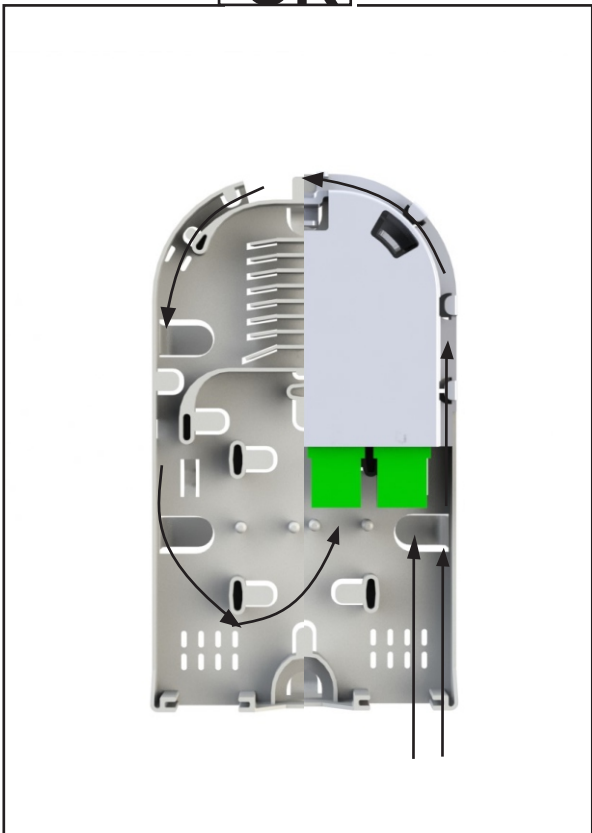

**Step #18** Secure bulkhead bracket into tray by positioning as below & pressing down until it clicks into place.

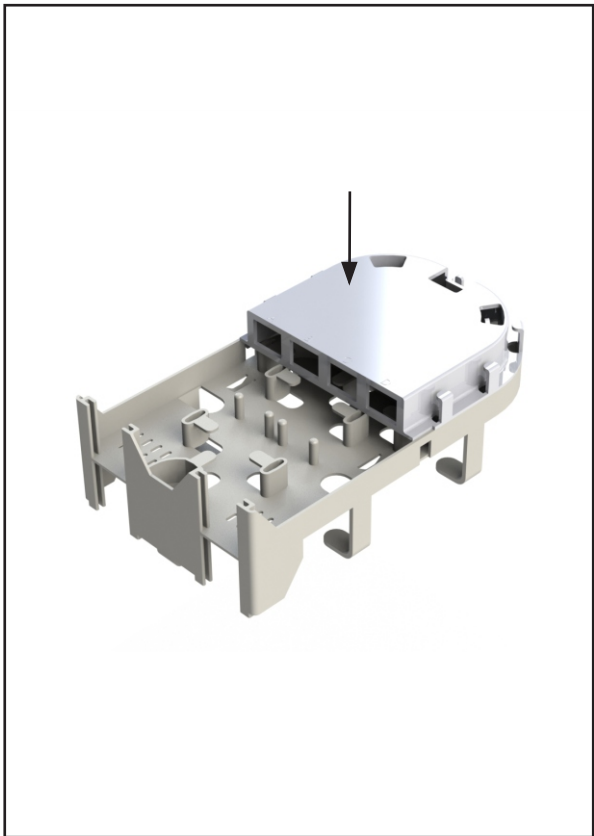
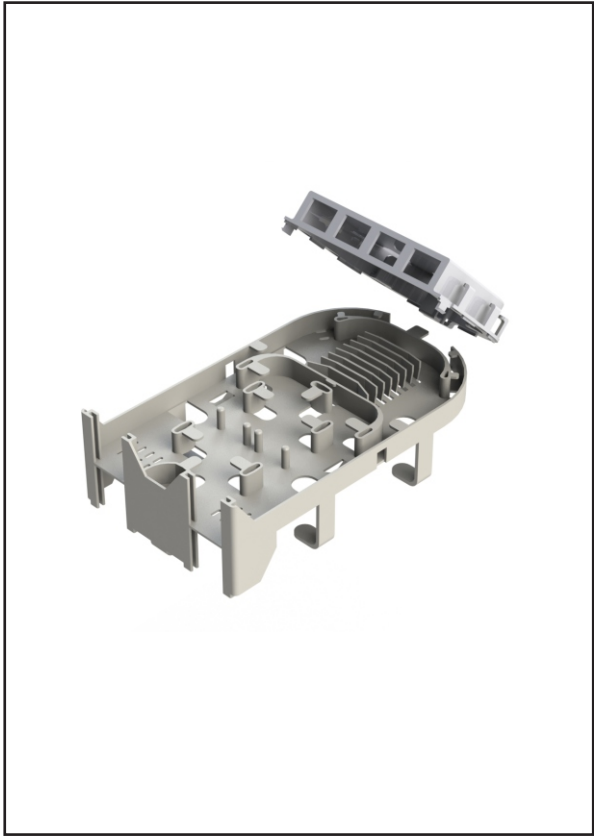

**NOTE:** Ensure pigtails exiting the bulkhead are routed under this tab (see image below) on the splice tray to avoid damaging cables.

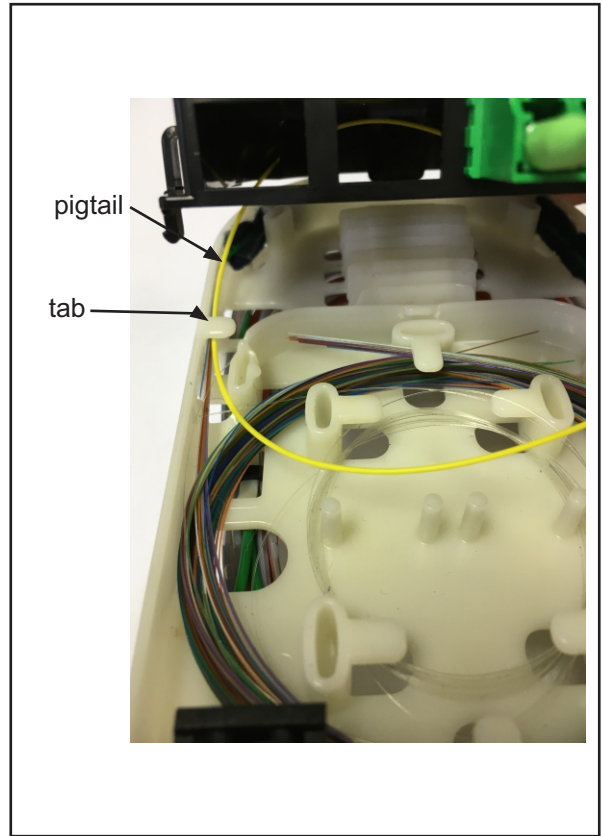

**Step #19** Lubricate all four outer surfaces of each grommet. Once the lubricant has been applied, smear it to provide a light coating on each surface.

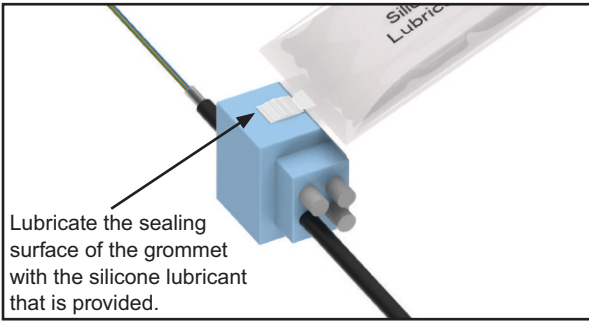

**Step #20** Insert the splice platform assembly into the base. Ensure to press down on the grommets & not the platform when inserting to avoid damaging fibers

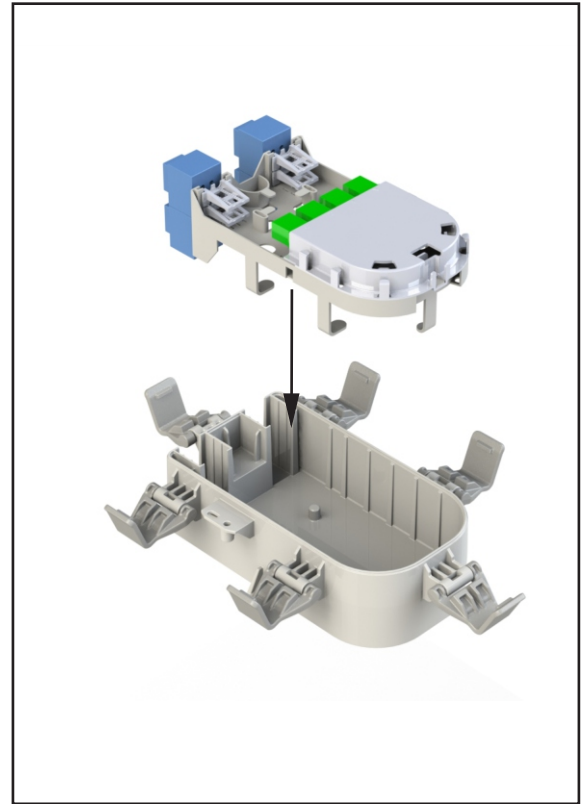



## Installation of Cover and Latches

**Step #21** Install the latches onto the base.

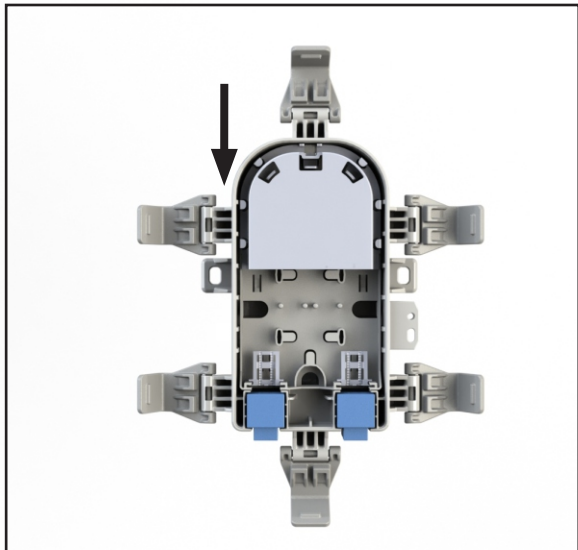

**Step #24** Secure the cover to the base with the security slot or use some other method that follows your standard company practice.

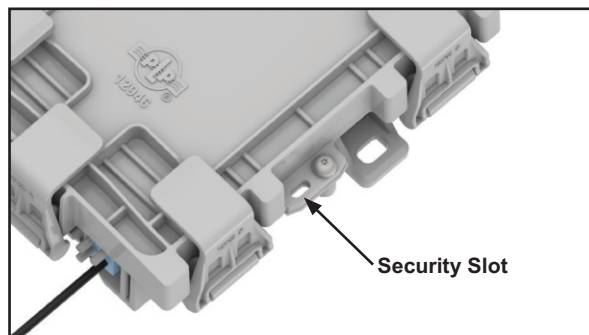

## Mounting in a Boundary Box

**Step #22** Store the fiber pick in the holder of the cover. Lubricate the cover gasket with a light coating of silicone lubricant.

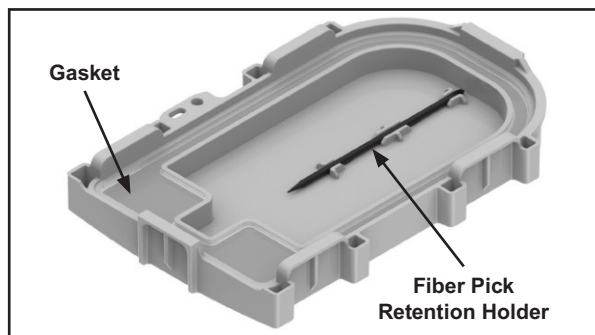

**Step #25** Secure the boundary box mounting bracket to the back of the base with the self-tapping screws provided.

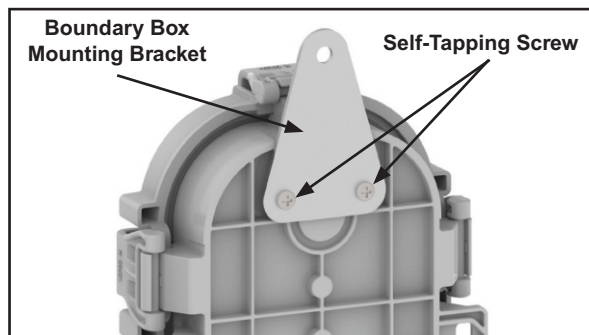

**Step #23** Place the cover on the base. Secure the cover by pressing down on it and rotating the latches until they snap in place over the cover.

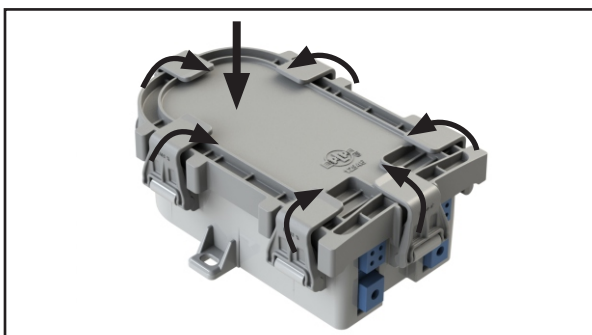

**Step #26** Hang the closure in the boundary box from the hook (not provided) as shown below.

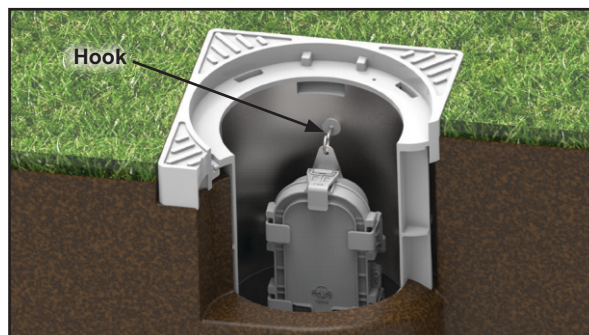

## SAFETY CONSIDERATIONS

This application procedure is not intended to supersede any company construction or safety standards. This procedure is offered only to illustrate safe application for the individual. **FAILURE TO FOLLOW THESE PROCEDURES MAY RESULT IN PERSONAL INJURY OR DEATH.**

**Do not modify this product under any circumstances.**

This product is intended for use by trained technicians only. **This product should not be used by anyone who is not familiar with, and not trained to use it.**

When working in the area of energized lines, extra care should be taken to prevent accidental electrical contact.

For proper performance and personal safety, be sure to select the proper size PREFORMED™ product before application.

PREFORMED products are precision devices. To insure proper performance, they should be stored in cartons under cover and handled carefully.



# PREFORMED LINE PRODUCTS



## USER INSTRUCTIONS

### STP-JR RETENTION CLIPS

Be sure to read and completely understand this procedure before applying product. Be sure to select the proper PREFORMED product before application.

#### STP-JR 2 HOLE RETENTION CLIP APPLICATION INSTRUCTIONS

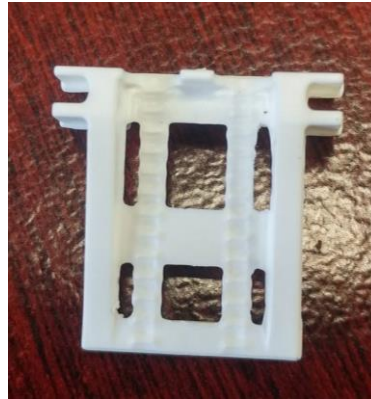

#### Step #1

MEASURE THE FELT AS SEEN BELOW AND APPLY THE APPROPRIATE AMOUNT OF FELT TO THE CABLE (DO NOT OVER APPLY FELT).

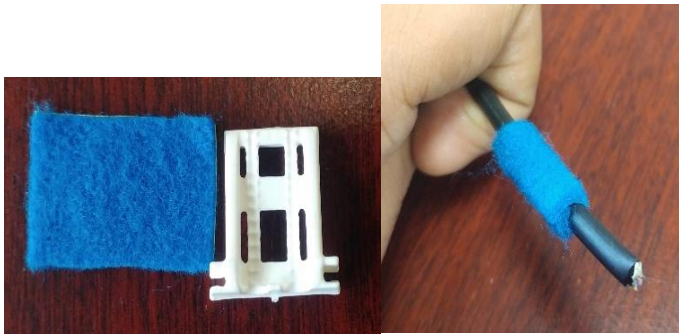

#### Step #2

THREAD THE FIRST TWO CABLE TIES IN THROUGH THE CENTER AND OUT THROUGH THE EDGE ENSURING THAT THE HEAD OF THE CABLE IS IN THE CENTER (ONE CABLE TIE GOING THROUGH THE TOP HALF AND THE OTHER THROUGH THE BOTTOM HALF). TIGHTEN THE CABLE TIES TIGHT ENSURING THE HEAD OF THE CABLE TIE FALLS TO THE OUTER EDGE OF THE CLIP

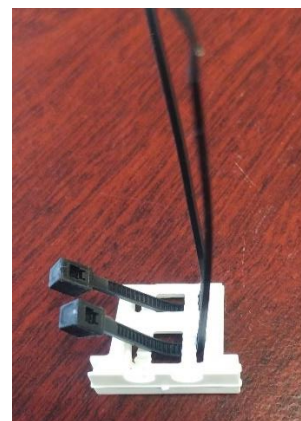

#### Step #3

THREAD THE NEXT TWO CABLES TIES THE SAME WAY AS THE FIRST TWO INSURING THE HEAD OF THE CABLE TIE IS IN THE CENTER





**Step #4**

REPEAT STEPS 1 & 2 TO SECURE THE SECOND CABLE TO THE RETENTION CLIP ENSURING ALL CABLE TIE HEADS ARE ROTATED TO THE SIDE.

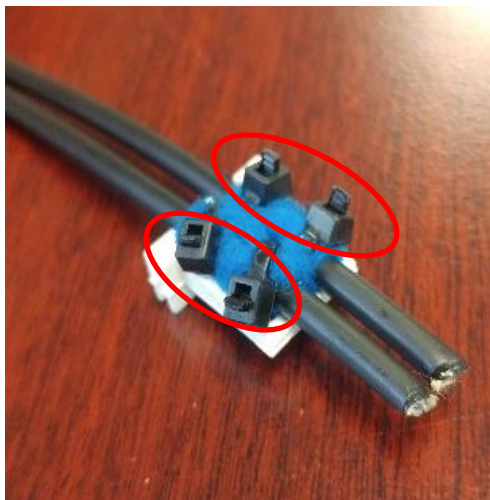

**Step #5**

REPEAT STEPS 1 TO 4 TO SECURE ANOTHER SET OF CABLES TO THE SECOND RETENTION CLIP IF NEEDED.

**Step #6**

SLIT THE GROMMET ALONG THE LENGTH INTO EACH GROMMET HOLE TO ALLOW THE CABLE TO BE INSERTED INTO THE GROMMET. SLIDE THE CABLES THROUGH THE SLITS AND POSITION THE CLIPS AS SEEN BELOW.

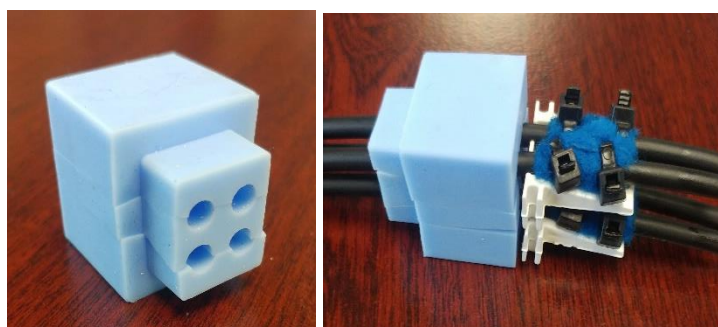

**Step #7**

INSERT THE ASSEMBLY INTO THE CORRECT SLOT SHOWN BELOW AND PRESS THE CLIPS DOWN UNTIL IT IS FLUSH WITH THE BASE AS SHOWN BELOW.

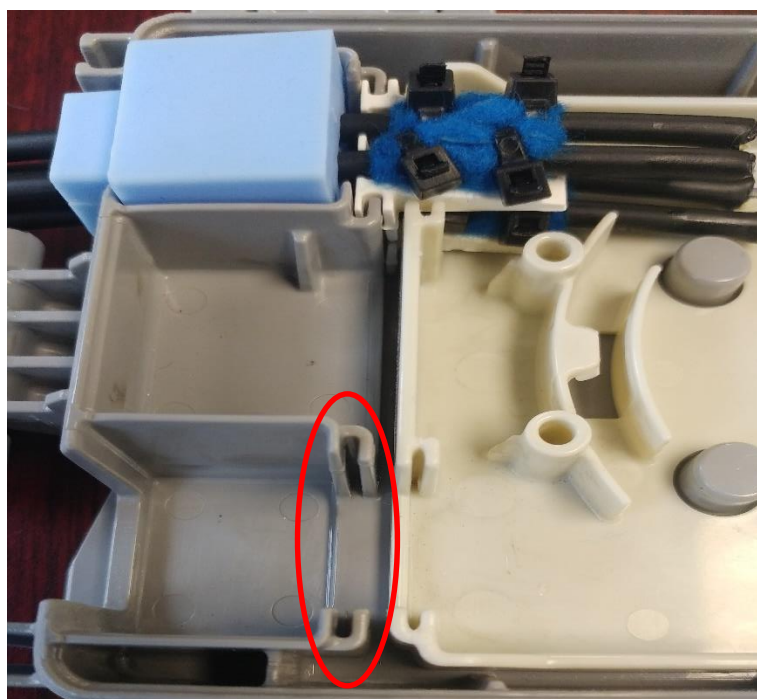



**STP-JR 1 HOLE RETENTION CLIP APPLICATION INSTRUCTIONS**



**Step #1**

MEASURE AND APPLY THE APPROPRAITE AMOUNT OF FELT TO THE CABLE (DO NOT OVER APPLY FELT).



**Step #2**

THREAD THE TWO CABLE TIES IN THROUGH ONE SIDE AND OUT THROUGH THE OTHER ENSURING THAT THE HEAD OF THE CABLE TIES ARE ONE SIDE (ONE CABLE TIE GOING THROUGH THE TOP HALF AND THE OTHER THROUGH THE BOTTOM HALF). TIGHTEN THE CABLE TIES TIGHT ENSURING THE HEAD OF THE CABLE TIE FALLS TO THE OUTER EDGE OF THE CLIP



**Step #3**

SLIT THE GROMMET ALONG THE LENGTH INTO EACH GROMMET HOLE TO ALLOW THE CABLE TO BE INSERTED INTO THE GROMMET. SLIDE THE CABLES THROUGH THE SLITS AND POSITION THE CLIPS AS SEEN BELOW.

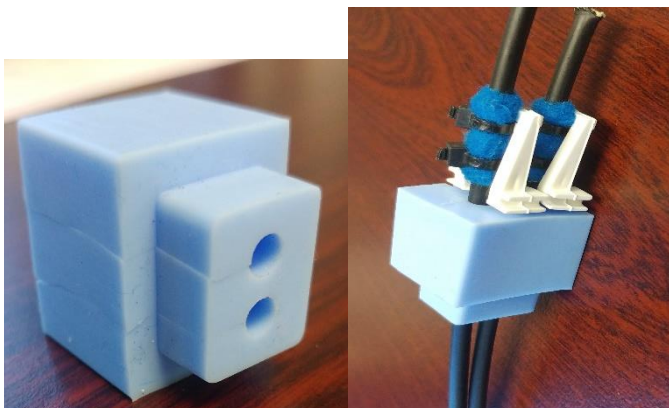



**Step #4**

**INSERT THE ASSEMBLY INTO THE CORRECT SLOT SHOWN BELOW AND PRESS THE CLIPS DOWN UNTIL IT IS FLUSH WITH THE BASE AS SHOWN BELOW.**

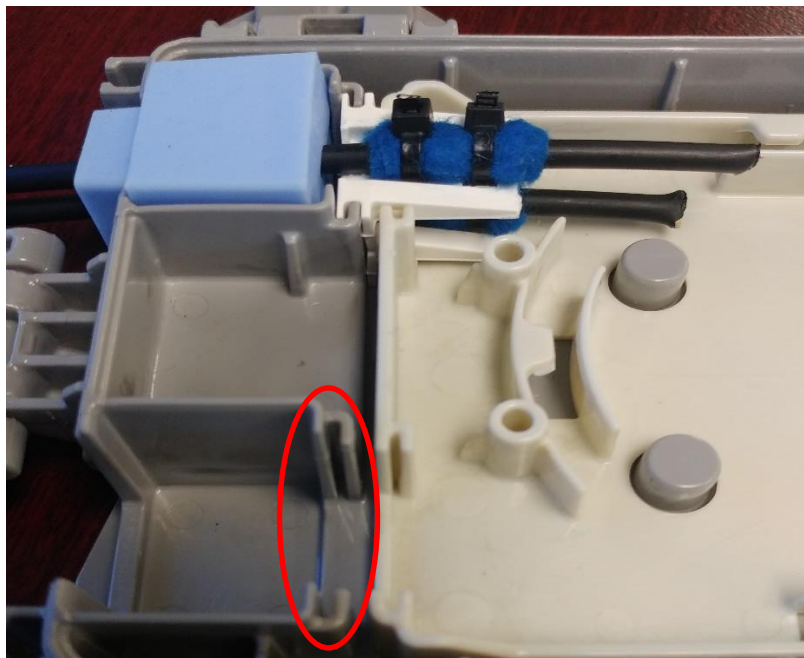

**SAFETY CONSIDERATIONS**

This application procedure is not intended to supersede any company construction or safety standards. This procedure is offered only to illustrate safe application for the individual. **FAILURE TO FOLLOW THESE PROCEDURES MAY RESULT IN PERSONAL INJURY OR DEATH.**

**Do not modify this product under any circumstances.**

**Helical products require a far reach in order to be applied completely. Care should be taken to ensure that the equipment used in conjunction with helical product installation can accommodate for the far reach required.**

This product is intended for use by trained technicians only. **This product should not be used by anyone who is not familiar with, and not trained to use it.**

When working in the area of energized lines, extra care should be taken to prevent accidental electrical contact.

For proper performance and personal safety, be sure to select the proper size PREFORMED™ product before application.

PREFORMED products are precision devices. To insure proper performance, they should be stored in cartons under cover and handled carefully.

