



**PREFORMED** LINE PRODUCTS  
The connection you can count on.

# Polymer Insulators

## A Better Solution



 COMMUNICATIONS  ENERGY  SPECIAL INDUSTRIES  SOLAR

October 2016

# LET'S CONNECT

## POLYMER INSULATORS

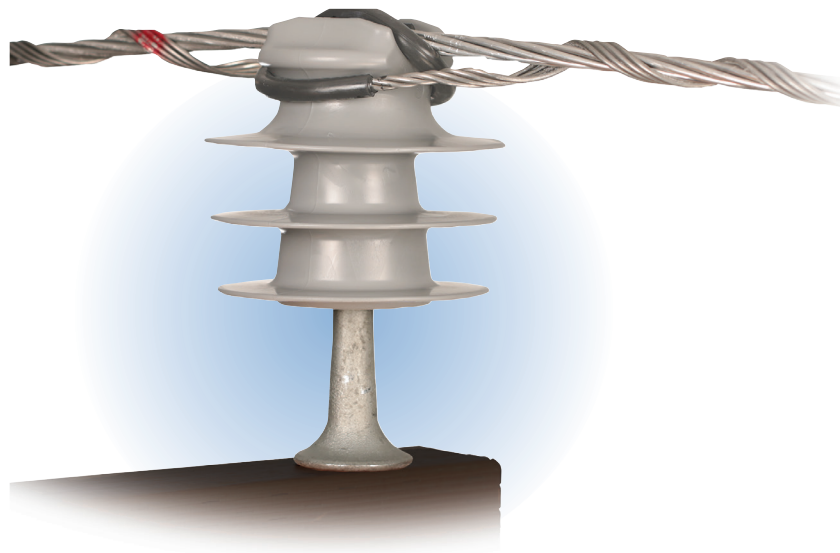

- Design derived from PLP's many years of worldwide experience and tested to adhere to ANSI C29.5 and ANSI 29.6 insulator standards
- Usable for any application that calls for porcelain or polymer pin insulators, and suitable for use with all types of jacketed or bare conductors.
- Currently available in a line of 15, 25 and 35kV Tie Top and Vise Top designs for 1" or 1-3/8" pins
- Specifically designed for use with PLP formed wire ties, plastic ties and hand tie wire
- Unique descending skirt design and polyethylene surface provide superior moisture and contamination shedding properties



**PREFORMED** LINE PRODUCTS

The connection you can count on.

440.461.5200 • [www.preformed.com](http://www.preformed.com) • [inquiries@preformed.com](mailto:inquiries@preformed.com)

# Polymer Insulators

---

## Table of Contents

Polymer Insulator Introduction ..... 1

Polymer Insulators – Tie Top ..... 2

Polymer Insulators – Vise Top ..... 6

Polymer Insulators – Accessories ..... 10

Polymer Insulators – Spool Insulators ..... 11

## Additional Polymer Insulator Information Available from PLP:

**SP3245** – Polymer Insulator: Tie Top Application Procedure

**SP3032** – Polymer Insulator: Vise Top (VT) Application Procedure

**EN-SS-1162** – Polymer Insulator: Vise Top Sell Sheet

**EN-SS-1132** – Polymer Insulator: Tie Top Sell Sheet



# Polymer Insulators

The **PLP Polymer Insulators** are for use in overhead distribution lines using bare or covered conductors. They are particularly suited for use with Spacer Cable and Tree Wire as a better electrical alternative to porcelain insulators.

PLP Polymer Insulators are manufactured from a proprietary, high-density polyethylene-based compound having a dielectric constant that is compatible with polyethylene-covered conductors.

These insulators are designed to meet the applicable dimensional, electrical, and mechanical requirements of the ANSI C29.5 and C29.6 pin-type insulator standards, even though these standards apply only to Wet-Process Porcelain Insulators. These insulators can be used in any application that calls for porcelain insulators requiring adherence to these ANSI standards.

Two basic designs are offered: Tie Top and Vise Top Insulators, both available for application on 1" or 1-3/8" pins depending upon the specific ANSI class or voltage application.

The Tie Top Insulators are designed to meet pertinent ANSI C29.5 and C29.6 insulator head dimensional standards for appropriate insulator classes with "C", "F" or "J" necks. Therefore, they are compatible with all PLP Formed Wire and Plastic Ties, and covered or bare tie wire.

The Vise Top Insulators employ a unique clamp style head. While they are also designed to meet certain ANSI standards, the clamp style head design is not applicable to ANSI tie top insulator head dimensional standards.

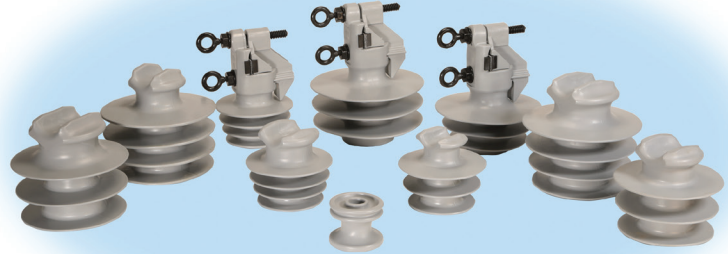

## BENEFITS

- ANSI compliant tie top head design facilitates the use of factory-formed ties for exceptional fit and performance matching.
- The Polymer Insulators closely match the dielectric properties of the covered conductor jacket.
- The polyethylene surface, coupled with the multiple skirt design with descending skirt diameters and long leakage distances, provides superior moisture and contamination shedding properties.
- UV-stabilized for long-term service.
- High impact resistance – designed to reduce breakage and vandal/gun shot damage, particularly at cold temperatures.
- The lightweight design reduces shipping costs and lineman handling requirements.
- Polyethylene material eliminates abrasion of the conductor at the insulator/conductor interface.
- Polymer Insulators can be used with jacketed jumper wires, eliminating skinning, and providing additional wildlife protection at equipment locations.

# Polymer Insulators – Tie Top

## ANSI Class: 55-3, 55-4, 55-5, 55-6, 55-7, 56-1

The PLP Tie Top Polymer Insulators are designed to match the head, neck and mounting pin requirements of ANSI C29.5, Class 55-3, 55-4, 55-5, 55-6, and 55-7 as well as ANSI C29.6, Class 56-1 pin-type insulator standards. "C" (2 -1/4" nominal), "F" (2-7/8" nominal) and "J" (3-1/2") neck sizes are available.

By using ANSI head and neck dimensional standards, PLP metal or plastic factory formed ties will install easily and provide superior holding and electrical performance on PLP Tie Top Polymer Insulators. Consult PLP for the suitability of other factory formed tie brands with these insulators.

Covered or bare hand tie wire is also suitable for use with PLP Tie Top Polymer Insulators depending on conductor type.



## FEATURES

- Tie top designs are perfect for use with all PLP ties
- Matched dielectric properties
- Superior moisture and contamination shedding
- UV stabilized material
- High impact resistance
- Lightweight design
- Head dimensions - ANSI compliant
- Dramatically reduces abrasion
- Ideal for jumpers and stinger wires
- 100% recyclable
- 1" or 1-3/8" pins

# Polymer Insulators – Tie Top

**ANSI Class:**  
**55-3, 55-4, 55-5, 55-6, 55-7, 56-1**



| Polymer Insulators Tie Top – Pin-Type |             |             |                          |
|---------------------------------------|-------------|-------------|--------------------------|
| PLP Catalog Number                    | ANSI Class* | Description | Mounting Pin Application |
| <b>15kV Applications</b>              |             |             |                          |
| IP-15-C**                             | 55-3        | C Neck      | 1"                       |
| IP-15-F**                             | 55-4        | F Neck      | 1"                       |
| <b>25kV Applications</b>              |             |             |                          |
| IP-25-F1                              | 55-5        | F Neck      | 1"                       |
| IP-25-F2                              | 55-5†       |             | 1-3/8"                   |
| IP-25-J1                              | 56-1†       | J Neck      | 1"                       |
| IP-25-J2**                            | 56-1        |             | 1-3/8"                   |
| <b>35kV Applications</b>              |             |             |                          |
| IP-35-F1                              | 55-6†       | F Neck      | 1"                       |
| IP-35-F2                              | 55-7†       |             | 1-3/8"                   |
| IP-35-J1                              | 55-6        | J Neck      | 1"                       |
| IP-35-J2                              | 55-7        |             | 1-3/8"                   |

\* Nominal ANSI C29.5 or C29.6 Class designation

\*\* RUS Accepted

† Meets the electrical requirements of the ANSI Class designation, but there are differences in the physical characteristics.

# Polymer Insulators – Tie Top

## Nominal Dimensions & PLP Formed Tie Applications

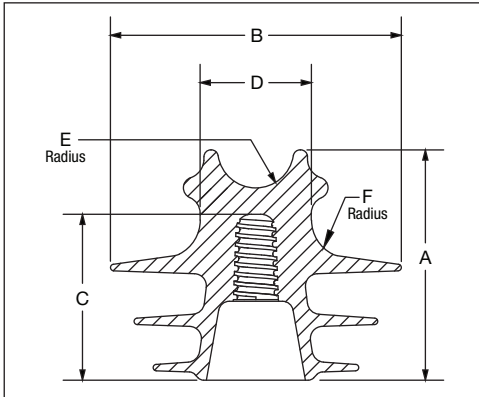

| Nominal Insulator Dimensions   |   |                    |                       |                       |                       |                        |
|--|---|--------------------|-----------------------|-----------------------|-----------------------|------------------------|
| Insulator Type<br>Catalog Number   | Tie Top<br>IP-15-C  | Tie Top<br>IP-15-F | Tie Top<br>IP-25-F1/2 | Tie Top<br>IP-25-J1/2 | Tie Top<br>IP-35-F1/2 | Vise Top<br>IP-35-J1/2 |
| <b>Dimensions (in)</b>   |   |                    |                       |                       |                       |                        |
| A  | 5.0   | 5.25               | 5.7                   | 6.7                   | 7.5                   | 7.5                    |
| B  | 5.5   | 5.5                | 6.1                   | 7.0                   | 7.5                   | 7.5                    |
| C  | 3.75  | 3.75               | 4.35                  | 4.9                   | 5.5                   | 5.5                    |
| D  | 2.25  | 2.875              | 2.875                 | 3.5                   | 2.875                 | 3.5                    |
| E (Radius)   | 0.75  | 1.0                | 1.0                   | 1.0                   | 1.0                   | 1.0                    |
| F (Radius)   | 0.65  | 0.65               | 0.65                  | 1.0                   | 0.75                  | 1.0                    |
| Number of Skirts   | 3   | 4                  | 3                     | 3                     | 4                     | 4                      |
| Maximum Conductor OD,<br>Top Groove  | 1.50  | 1.875              | 2.0                   | 2.00                  | 2.00                  | 2.00                   |
| Maximum Conductor OD,<br>Side Groove   | 1.30  | 1.30               | 1.30                  | 2.00                  | 1.50                  | 2.00                   |
| PLP Tie  | Maximum Conductor Outer Diameter (in) with PLP Factory Formed Ties* |                    |                       |                       |                       |                        |
| Distribution Tie   | 1.25  | 1.75               | 1.75                  | 1.75                  | 1.75                  | 1.75                   |
| WRAPLOCK® Tie  | 1.25  | 1.75               | 1.75                  | 1.75                  | 1.75                  | 1.75                   |
| EZ-WRAP® Twin Tie  | 1.25  | 1.75               | 1.75                  | 1.75                  | 1.75                  | 1.75                   |
| Double Support Tie   | 1.25  | 1.75               | 1.75                  | 1.75                  | 1.75                  | 1.75                   |
| Side Tie   | 1.05  | 1.05               | 1.25                  | 1.75                  | 1.25                  | 1.75                   |
| EZ-WRAP® Side Tie  | 1.05  | 1.05               | 1.25                  | 1.75                  | 1.25                  | 1.75                   |
| Double Side Tie  | 1.05  | 1.05               | 1.25                  | 1.75                  | 1.25                  | 1.75                   |
| Plastic Top Tie;<br>Jacketed Cond.   | 1.50  | 2.00               | 2.00                  | 2.00                  | 2.00                  | 2.00                   |
| Plastic Side Tie;<br>Jacketed Cond.  | 1.30  | 1.30               | 1.30                  | 2.00                  | 1.50                  | 2.00                   |
| *For some Formed Ties it is necessary to reduce Max Conductor OD that can fit into the insulator groove because allowance needs to be made for tie tube thickness &/or wires of the tie may take up space in the groove. |   |                    |                       |                       |                       |                        |





# Polymer Insulators – Vise Top

## **ANSI Class: 55-3, 55-4, 55-5, 55-6, 55-7**

The PLP Vise Top Insulator utilizes a unique plastic clamp mechanism and nylon torque bolts to secure the conductor. The nylon torque bolt with break-away ring is designed to ensure that the optimal holding force is applied while providing for a fast conductor clamping.

Compatible conductor inserts for either jacketed or bare conductor are available. Nylon inserts are offered for use with jacketed conductors. Bronze inserts are offered for bare copper conductors, and aluminum inserts are offered for bare aluminum conductors.

PLP also offers a Universal Insert design\* which is compatible with all conductors. It is recommended that the utility determine the suitability of the PLP Vise Top Polymer Insulators on bare conductor before installation.



## **FEATURES**

- Superior moisture and contamination shedding
- UV stabilized material
- High impact resistance
- Lightweight design
- Ideal for jumpers and stinger wires
- 100% recyclable
- 1" or 1-3/8" pins
- Performance matched inserts for bare conductor
- Universal Insert design\* to reduce the number of different insulators required
- Ideal for use with shot gun sticks
- Vise Top Stringing Tool available

**\*Patent Pending**

# Polymer Insulators – Vise Top

## ANSI Class:

55-3, 55-4, 55-5, 55-6, 55-7



| Universal Vise Top Insulators† – Pin Type |             |           |                            |                       |
|---|-------------|-----------|----------------------------|-----------------------|
| PLP Catalog Number                        | ANSI Class* | Insert    | Application                | Mounting Pin Diameter |
| <b>15kV</b>                               |             |           |                            |                       |
| IP-15-VTU                                 | 55-3, 55-4  | Universal | All Conductor Applications | 1"                    |
| <b>25kV</b>                               |             |           |                            |                       |
| IP-25-VTU1                                | 55-5        | Universal | All Conductor Applications | 1"                    |
| IP-25-VTU2                                |             |           |                            | 1-3/8"                |
| <b>35kV</b>                               |             |           |                            |                       |
| IP-35 -VTU1                               | 55-6        | Universal | All Conductor Applications | 1"                    |
| IP-35 -VTU2                               | 55-7        |           |                            | 1-3/8"                |

| Vise Top Insulators – Pin Type |             |          |                          |                       |
|--------------------------------|-------------|----------|--------------------------|-----------------------|
| PLP Catalog Number             | ANSI Class* | Insert   | Application              | Mounting Pin Diameter |
| <b>15kV</b>                    |             |          |                          |                       |
| IP-15-VTN                      | 55-3, 55-4  | Nylon    | Jacketed Conductors      | 1"                    |
| IP-15-VTM                      |             | Aluminum | Bare Aluminum Conductors |                       |
| IP-15-VTM-B                    |             | Bronze   | Bare Copper Conductors   |                       |
| <b>25kV</b>                    |             |          |                          |                       |
| IP-25-VTN1                     | 55-5        | Nylon    | Jacketed Conductors      | 1"                    |
| IP-25-VTN2                     |             |          |                          | 1-3/8"                |
| IP-25-VTM1                     |             | Aluminum | Bare Aluminum Conductors | 1"                    |
| IP-25-VTM2                     |             |          |                          | 1-3/8"                |
| IP-25-VTM1-B                   |             | Bronze   | Bare Copper Conductors   | 1"                    |
| IP-25-VTM2-B                   |             |          |                          | 1-3/8"                |
| <b>35kV</b>                    |             |          |                          |                       |
| IP-35 -VTN1                    | 55-6        | Nylon    | Jacketed Conductors      | 1"                    |
| IP-35 -VTN2                    | 55-7        |          |                          | 1-3/8"                |
| IP-35 -VTM1                    | 55-6        | Aluminum | Bare Aluminum Conductors | 1"                    |
| IP-35 -VTM2                    | 55-7        |          |                          | 1-3/8"                |
| IP-35 -VTM1-B                  | 55-6        | Bronze   | Bare Copper Conductors   | 1"                    |
| IP-35 -VTM2-B                  | 55-7        |          |                          | 1-3/8"                |

\*Nominal ANSI C29.5 Class Specifications

†Patent Pending

# Polymer Insulators – Vise Top

## Nominal Dimensions

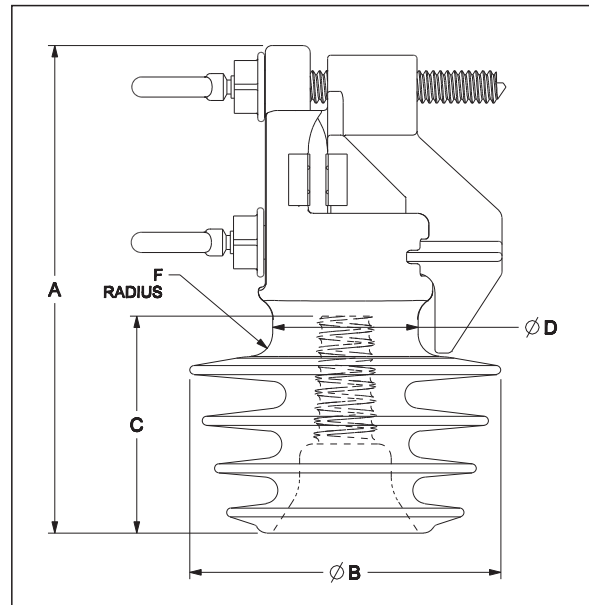

| Nominal Insulator Dimensions                     |                            |                            |                            |
|--|----------------------------|----------------------------|----------------------------|
| Insulator Type<br>Catalog Number                 | Vise Top<br>IP-15-VT (all) | Vise Top<br>IP-25-VT (all) | Vise Top<br>IP-35-VT (all) |
| <b>Dimensions (in)</b>                           |                            |                            |                            |
| A  | 8.5                        | 8.4                        | 10.125                     |
| B  | 5.5                        | 7.3                        | 8.0                        |
| C  | 3.75                       | 4.5                        | 5.375                      |
| D  | 2.50                       | 2.50                       | 2.50                       |
| F (Radius)                                       | 0.5                        | 0.5                        | 0.5                        |
| Number of Skirts                                 | 4                          | 3                          | 3                          |
| Tangent Vise Attachment,<br>Maximum Conductor OD | 1.875                      | 1.875                      | 1.875                      |
| Side Groove,<br>Maximum Conductor OD             | 1.0                        | 1.0                        | 1.0                        |

# Polymer Insulators – Vise Top

## Test Results Based on ANSI C29 Standards

| Insulator Data                            | 15kV Applications      |                                | 25kV Applications          |                          |                           | 35kV Applications          |                           |                          |                           |
|---|------------------------|--------------------------------|----------------------------|--------------------------|---------------------------|----------------------------|---------------------------|--------------------------|---------------------------|
|   | PLP PI                 | ANSI C29.5 55-3/55-4 Standards | PLP PI                     | PLP PI                   | ANSI C29.5 55-5 Standards | PLP PI                     | ANSI C29.5 55-6 Standards | PLP PI                   | ANSI C29.5 55-7 Standards |
| Catalog Number & Application              | IP-15-VTN/M/U Vise Top | NA                             | IP-25-VTN/M/U-1 Vise Top   | IP-25-VTN/M/U-2 Vise Top | NA                        | IP-35-VTN/M/U-1 Vise Top   | NA                        | IP-35-VTN/M/U-2 Vise Top | NA                        |
| "Nominal" ANSI Class                      | 55-3                   | 55-3/55-4                      | 55-5                       | 55-5                     | 55-5                      | 55-6                       | 55-6                      | 55-7                     | 55-7                      |
| Neck Size/Style                           | NA                     | C/F                            | NA                         | NA                       | F                         | NA                         | F/J                       | NA                       | F/J                       |
| Typical Operating Voltage Application, kV | 15                     | 15                             | 25                         | 25                       | 25                        | 35                         | 35                        | 35                       | 35                        |
| Leakage Distance (in)                     | 16.1                   | 7/9                            | 18.1                       | 17.9                     | 12                        | 23.5                       | 15                        | 23.3                     | 15                        |
| Dry Arcing Distance (in)                  | 7                      | 4.5/5                          | 8.7                        | 8.5                      | 6.25                      | 10.6                       | 8                         | 10.4                     | 8                         |
| Pin Hole Diameter (in)                    | 1                      | 1                              | 1                          | 1 3/8                    | 1                         | 1                          | 1                         | 1 3/8                    | 1 3/8                     |
| Suggested Minimum Pin Length (in)         | 6                      | 5                              | 6                          | 6                        | 6                         | 7.5                        | 7.5                       | 7.5                      | 7.5                       |
| 60Hz Dry Flashover (kV)                   | 101(N)<br>95(M)        | 55/65                          | 88(N) (1)<br>94(M) (1)     | 88(N)<br>94(M)           | 85                        | 128(N) (1)<br>115(M) (1)   | 100                       | 128(N)<br>115(M)         | 100                       |
| 60 Hz Wet Flashover (kV)                  | 50 (N)<br>64(M)        | 30/35                          | 55(N) (1)<br>55(M) (1)     | 55(N)<br>55(M)           | 45                        | 72 (N) (1)<br>80(M) (1)    | 50                        | 72 (N)<br>80(M)          | 50                        |
| Positive Impulse Flashover (kV)           | 147(N)<br>154(M)       | 90/105                         | 150(N) (1)<br>152(M) (1)   | 150(N)<br>152(M)         | 140                       | 188(N) (1)<br>196(M) (1)   | 150                       | 188(N)<br>196(M)         | 150                       |
| Negative Impulse Flashover (kV)           | -201(N)<br>-200(M)     | -110/-130                      | -219(N) (1)<br>-216(M) (1) | -219(N)<br>-216(M)       | -170                      | -272(N) (1)<br>-261(M) (1) | -170                      | -272(N)<br>-261(M)       | -170                      |
| Low Frequency Puncture (kV)               | 174(N)<br>163(M)       | 90/95                          | 228(N)<br>218(M)           | 191(N)<br>184(M)         | 115                       | 206(N)<br>207(M)           | 135                       | 219(N)<br>209(M)         | 135                       |
| <b>RIV @ 1 MHz</b>                        |                        |                                |                            |                          |                           |                            |                           |                          |                           |
| 10kV to grd, $\mu$ V                      | <4                     | <50 $\mu$ V @10kV              | NA                         | NA                       | NA                        | NA                         | NA                        | NA                       | NA                        |
| 15kV to grd, $\mu$ V                      | NA                     | NA                             | <0.5 (1)                   | <0.5                     | <100 $\mu$ V @15kV        | NA                         | NA                        | NA                       | NA                        |
| 22kV to grd, $\mu$ V                      | NA                     | NA                             | NA                         | NA                       | NA                        | <6 (1)                     | <100 $\mu$ V @22kV        | <6                       | <100 $\mu$ V @22kV        |
| Cantilever Strength (lbs)                 | 3000                   | 3000                           | 3000                       | 3000                     | 3000                      | 3000                       | 3000                      | 3000                     | 3000                      |
| Approximate Weight (lbs)                  | 2                      | NA                             | 2.3                        | 2.3                      | NA                        | 3                          | NA                        | 3.2                      | NA                        |
| Maximum Operating Temperature (Degree C)  | 120                    | NA                             | 120                        | 120                      | NA                        | 120                        | NA                        | 120                      | NA                        |

(1) Electrical test data extrapolated from similar design polymer insulator with 1-3/8" pin hole

# Polymer Insulators – Vise Top Accessories

## Torque Bolts:

Two torque bolts are supplied with each Vise Top insulator. The breakaway torque ring is designed to ensure the proper torque and optimum holding force to the conductor will be applied during initial installation. All Vise Top insulators use the same torque bolt.

New torque bolts should be used whenever conductors are removed from the Vise Top Insulator or any time the bolts are unscrewed and initial torque is lost. Individual torque bolts are available for replacement as needed.



PT-01

## Torque Bolt Hook Tool:

An aluminum hook tool accessory is offered for use with hydraulic or power wrenches for easy installation of torque bolts. However the tool should be operated at low speeds. A standard shotgun stick is ideal for the installation of the torque bolts.



VTHT-01

## Vise Top Stringing Tool:

The polyurethane Vise Top String Tool (VLST) is offered to aid jacketed conductor installation. The VLST temporarily installs in the Vise Top clamp, by hand or with hot sticks, and is designed to permit short span, low tension jacketed conductor stringing without the need for stringing wheels.

The tool is not recommended for use with bare conductors, long spans, or line, or sag angles over approximately 10°. A proper size stringing block should be used at the 1st and last pole, at large line or sag angles, or long spans throughout the pull, rather than the tool.

It is recommended that harsh material pulling ropes, such as nylon, be avoided to minimize excessive wear to the inner surface of the tool. It is also suggested low pulling speeds be used when pulling rope or cable through the tool to avoid excessive wear.

The tool can be reused, however, it is recommended the tool be inspected after each pull to insure it is suitable for further use. Areas of wear on the tool from previous pulls can be rotated away from where the rope and conductors will rest in the bore during subsequent pulls. Do not reuse the tool if there has been excessive wear throughout all areas of the inner bore.



IP-VLST-01



# Polymer Insulators – Spool Insulators

**PLP Polymer Spool Insulators** are used to insulate and support primary neutral and secondary (bare or covered) conductors at the pole or house using various clevis mounting configurations. They are compatible with all clevis manufacturers' hardware designs that are to be used with the ANSI C29.3 Class 53-2 spool insulators. They are designed to be used with PLP Spool Ties and EZ-WRAP™ Spool Ties. It is a direct replacement for porcelain spool insulators.

The IP-53-2 spool insulator is manufactured in the USA of a proprietary polyethylene material. This material is UV stabilized and is very resistant to breaking, chipping and cracking. The insulators are lightweight, at 0.34 lbs., and, like all the PLP Polymer Insulators, are fully recyclable.



**RUS ACCEPTED**

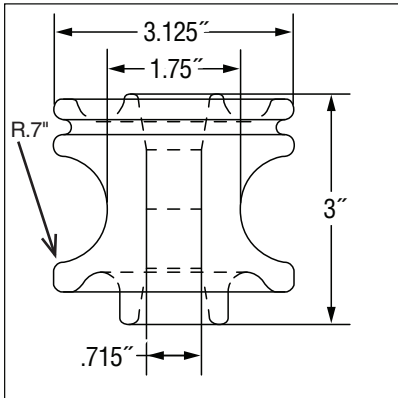

### BENEFITS

- Exceeds ANSI Class 53-2 electrical requirements
- Made in the USA
- Lightweight
- Resistant to cracking, chipping and vandals
- Fully UV stabilized
- 100% recyclable
- Long service life without deterioration
- Compatible with all manufacturers' pole hardware
- Compatible with all PLP factory formed spool ties

| Catalog Number | Description  | Carton |              |
|----------------|--|--------|--------------|
|                |  | Qty.   | Weight (lbs) |
| IP-53-2        | Polymer Spool Insulator 1-3/16" Neck Diameter – A Neck | 48     | 20           |



**PREFORMED**  
LINE PRODUCTS

World Headquarters  
660 Beta Drive  
Cleveland, Ohio 44143

Mailing Address:  
P.O. Box 91129  
Cleveland, Ohio 44101

Telephone: 440.461.5200  
Fax: 440.442.8816  
Web Site: [www.preformed.com](http://www.preformed.com)  
E-mail: [inquiries@preformed.com](mailto:inquiries@preformed.com)

© 2016 Preformed Line Products  
Printed in U.S.A.  
EN-ML-1022-9  
10.16.IH