



COYOTE® 9.5" x 19" (292 mm x 509 mm) Terminal Dome Closure











Be sure to read and completely understand this procedure before applying product. Be sure to select the proper PREFORMED product before application.



NOMENCLATURE

- | | | |
|---|--|--|
| 1. Dome Cover (1) | 6. Long Strength Member Bracket (2) | 12. Silicone Lubricant (4 five gram packets) |
| 2. Organizer Assembly with Hardened Adapter End Plate (1) | 7. Short Strength Member Bracket (2) | 13. Storage Bracket Retainer Clips (4) |
| 3. LITE-GRIP® Short Splice Tray (1) | 8. Large Strength Member Adapter Kit (1) | 14. Nut (11) |
| 4. Dome Collar (1) | 9. Transition Tube Kit (1) | 15. Lock Washer (11) |
| 5. Dome Gasket (1) | 10. Grommet (4) | 16. Pigtail Kit (1-2 depending on closure kit) |
| | 11. Hose Clamp (4) | |

COYOTE 9.5" x 19" (292 mm x 509 mm) Terminal Dome Closure Kits	
Catalog Number	Description
COYTD919B0-000	COYOTE 9.5" x 19" Terminal Dome Closure with 0 Hardened Adapters– Buffer Tube Applications
COYTD919B2-000	COYOTE 9.5" x 19" Terminal Dome Closure with 2 Hardened Adapters– Buffer Tube Applications
COYTD919B4-000	COYOTE 9.5" x 19" Terminal Dome Closure with 4 Hardened Adapters– Buffer Tube Applications
COYTD919B6-000	COYOTE 9.5" x 19" Terminal Dome Closure with 6 Hardened Adapters– Buffer Tube Applications
COYTD919B8-000	COYOTE 9.5" x 19" Terminal Dome Closure with 8 Hardened Adapters– Buffer Tube Applications
COYTD919R0-000	COYOTE 9.5" x 19" Terminal Dome Closure with 0 Hardened Adapters– Ribbon Applications
COYTD919R2-000	COYOTE 9.5" x 19" Terminal Dome Closure with 2 Hardened Adapters– Ribbon Applications
COYTD919R4-000	COYOTE 9.5" x 19" Terminal Dome Closure with 4 Hardened Adapters– Ribbon Applications
COYTD919R6-000	COYOTE 9.5" x 19" Terminal Dome Closure with 6 Hardened Adapters– Ribbon Applications
COYTD919R8-000	COYOTE 9.5" x 19" Terminal Dome Closure with 8 Hardened Adapters– Ribbon Applications
Accessory Kits	
80808456	COYOTE Dome End Plate Fixture
8003715	Hardened Adapter Kit with Installation Tool
8003724	Plug Kit with Installation Tool
80807972	Adapter Installation Tool
Mounting Brackets	
8003940	Aerial Mounting Bracket (Dome Mount)
8003941	Aerial Mounting Bracket (End Plate Mount)
8003940	Aerial Hanger Bracket Kit (For Strand)
8003869	Aerial Hanger Bracket Kit (For ADSS)
8003942	Pole/Wall Mounting Bracket
8004000	Hand Hole Dome Mounting Bracket

COYOTE® Grommet Chart			
For use in COYOTE GLC, Aerial, LCC, Dome, In-Line RUNT, Taut & Terminal Closures			
PLP Catalog Number	Cable Range Inches (mm)	Description	Splitting Location
8003691	.42 - .60 (11 - 15 mm)	1-entry grommet	
8003692	.60 - .85 (15 - 22 mm)	1-entry grommet	
8003693	.85 - 1.0 (22 - 25 mm)	1-entry grommet	
8003694	1.0 - 1.25 (25 - 32 mm)	1-entry grommet	
8003663	.42 - .60 (11 - 15 mm)	2-entry grommet	
8003664	.30 - .43 (8 - 11mm)	4-entry grommet	
8003989	Flat Drop Only	4-entry grommet	
8003665	.125 - .25 (3 - 6 mm)	6-entry grommet	
8003676	.42 - .60 (11 - 15 mm) .125 - .25 (3 - 6 mm)	7-entry grommet	
8003677	.125 - .25 (3 - 6 mm)	8-entry grommet	

NOTE: Grommet Kit contains (1) Grommet, (1) Cable Measure Tape, (2) Silicone Lubricant Packs, (1) Set of Plugs & (1) Glove

Splice Tray/Closure Capacities for COYOTE 9.5" x 19" (292 mm x 509 mm) Terminal Dome Closure						
Splice Tray	Catalog Number	Splice Type	Trays per Closure		Closure Splice Capacity	
			Buffer Tube	Ribbon	Buffer Tube	Ribbon
Low Profile LITE-GRIP® (24 ct)	80809958	Single Fusion	11	6	264	144
Standard (12 ct)	80806033	Single Fusion or Mechanical	8	4	96	48
Deep Profile LITE-GRIP® (40 ct)	80808945	Single Fusion	5	3	200	120
Deep Profile LITE-GRIP® (144 ct)	LGSTR144	Mass Fusion/ Ribbon	N/A	3	N/A	432

END PLATE PREPARATION

Step #1 Remove end plate from organizer.

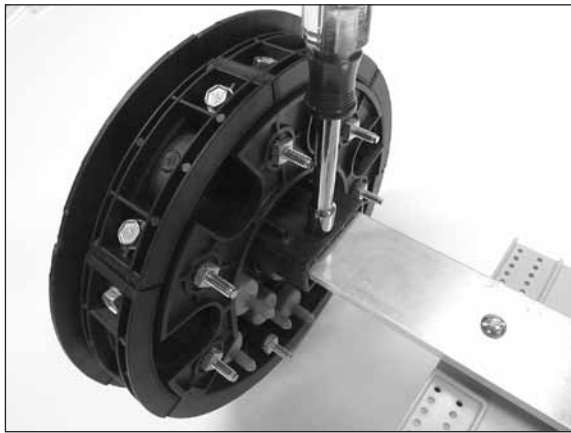

Step #2 Remove the end plate caps from each cable port and break out all cable port tabs.

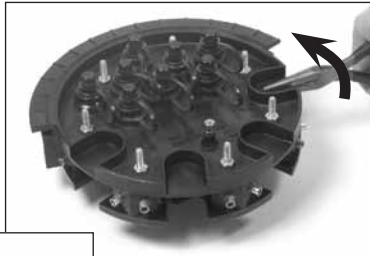

PLP Tip: Scoring edges of tabs with knife makes them break out easier.

End plate with all cable port tabs removed.

Step #3 Determine which cable ports will be used.

NOTE: If buffer tubes are routed in bottom storage brackets, use cable ports 2 & 3. If ribbon cables are being used or buffer tubes are routed in side storage brackets, use cable ports 1 & 4.

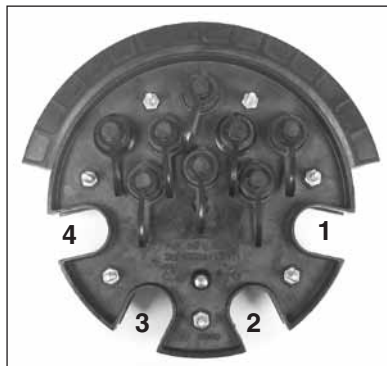

CABLE PREPARATION

Step #4 Measure cable to determine diameter and hole location to use in grommet.



Step #5 If using cut cable, insert cable through grommet. If your application requires express/balloon/ring cut cables, see Step 7 for grommet slitting procedure.

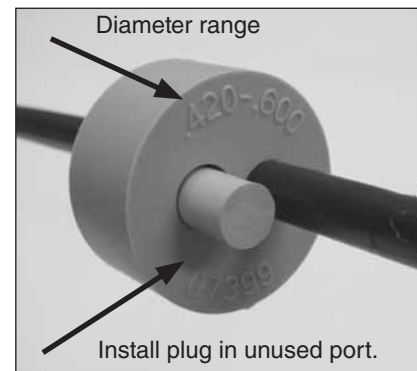

Step #6 **Installing Figure 8 Style Cables and Cables with Tracer Wires** - Remove tracer wire or ground wire from the portion of the cable that will be positioned in the grommet and insert cable into grommet.

Cable with Tracer Wire

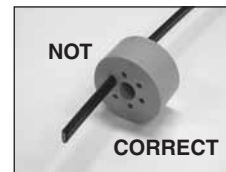

Not Correct Installation



Correct Installation

Figure 8 Style Cable

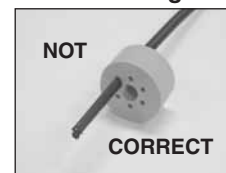

Not Correct Installation



Correct Installation

Step #7 Grommet Slitting – If slitting is required, lay grommet on a stable flat surface. Position utility knife with the cutting edge against the top surface and cut through grommet. **Consult grommet chart on page 2 for slitting locations of all grommets.**

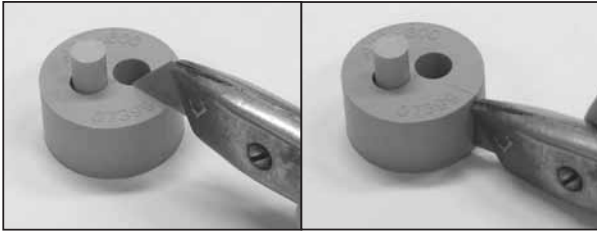

PLP Tip: Use a pen to sketch slitting lines on top surface of grommet prior to cutting.

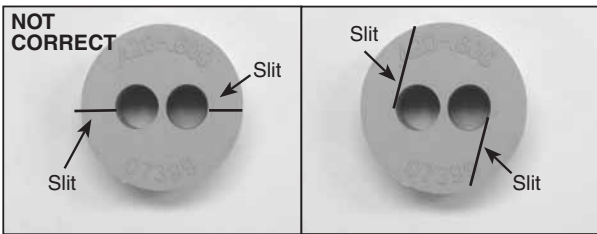

Not Correct Slitting Angle

Correct Slitting Angle

Step #8 Prepare loose tube/buffer tube or unitube/ribbon cable(s) for cut applications.



Minimum Sheath Opening for Cut Cable Applications

77" Min.	2.0 m Min.
----------	------------

PLP Tip: Leave about 8" (203 mm) of strength member to trim later.

Step #9 Prepare loose tube/buffer tube or unitube/ribbon cable(s) for mid sheath applications (Express/Balloon/Ring Cut).

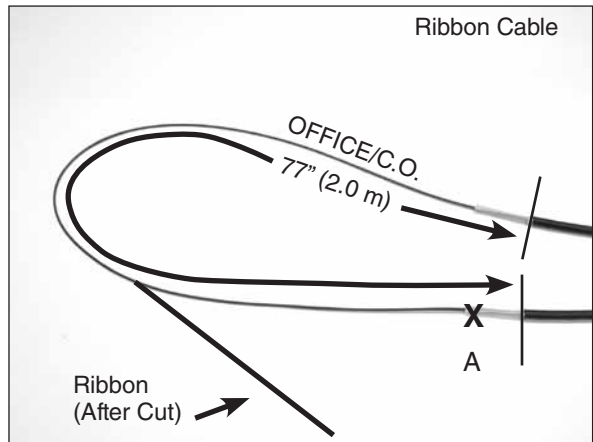
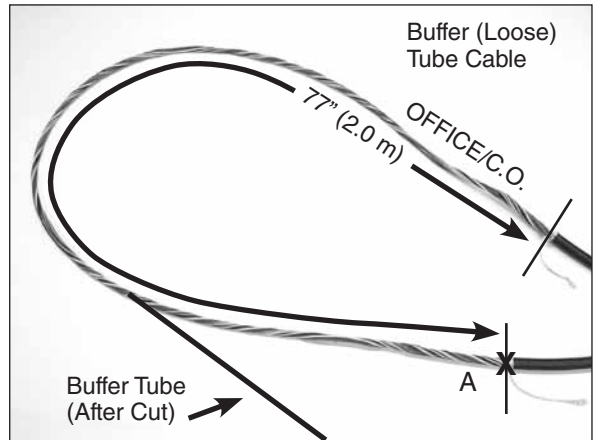

NOTE: When expressing ribbons in the transition tray of the closure at this measurement, the maximum number of ribbons that can be expressed is 24 ribbons (288 fibers).

For Applications Where Fiber is Dedicated to the Splice Point

Sheath Opening	77" (2.0 m) Min.
Fiber/Buffer Tube Cut Location	A (see image above)

PLP Tip: Leave about 8" (203 mm) of strength member to trim later.

Step #10 Prepare loose tube/buffer tube or unitube/ribbon cable(s) for mid sheath applications (Express/Balloon/Ring Cut).

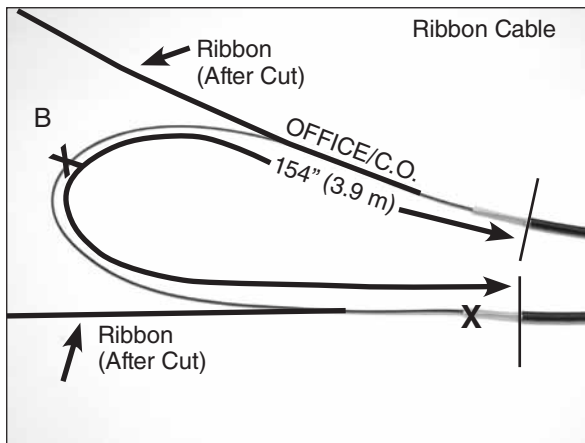
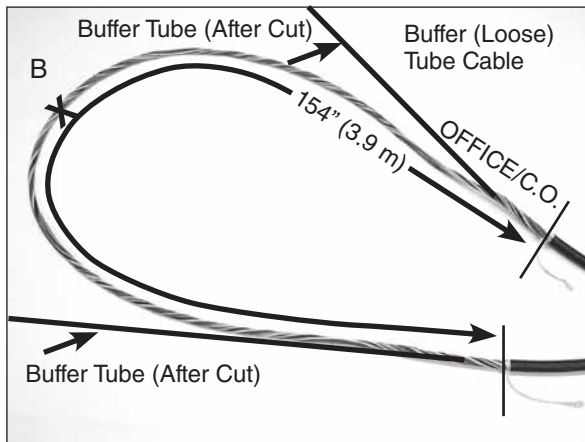

NOTE: When expressing ribbons in the transition tray of the closure at this measurement, the maximum number of ribbons that can be expressed is 12 ribbons (144 fibers).

For Applications Where Fiber is NOT Dedicated to the Splice Point	
Sheath Opening	154" (3.9 m) Min.
Fiber/Buffer Tube Cut Location	B (see image above)

PLP Tip: Leave about 8" (203 mm) of strength member to trim later.

Step #11 Prepare loose tube/buffer tube cable(s) for expressed fiber (buffer tube window cut)

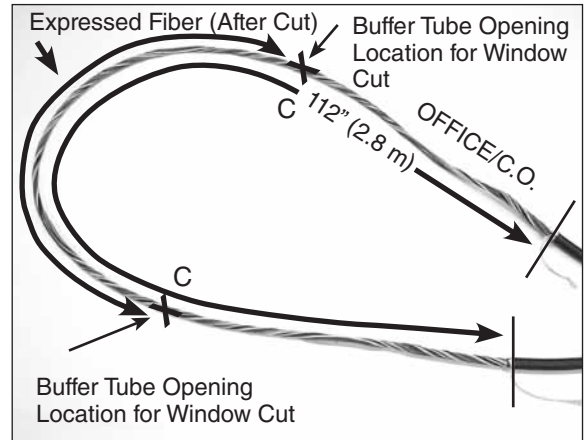

For Applications Where Fiber is Expressed through the Buffer Tube.

Sheath Opening	112" (2.8 m) Min.
Buffer Tube Window Cut Locations	C (see image above)

PLP Tip: Leave about 8" (203 mm) of strength member to trim later.

Step #12 Prepare Central/Buffer Tube(s) for Unitube/Ribbon Cable Applications

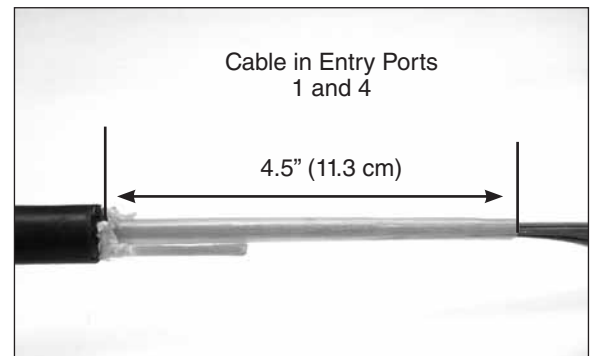

Step #13 If the cable contains Kevlar®, braid roughly 3" (7.2 cm) of the Kevlar.

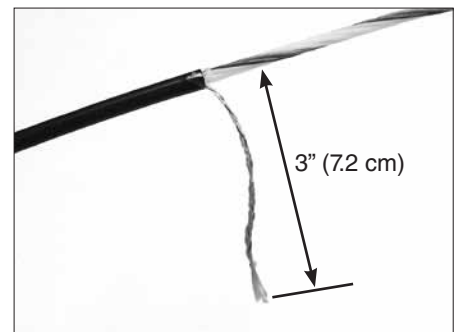

Step #14 Align sheath opening with end of slot of the strength member bracket as shown.

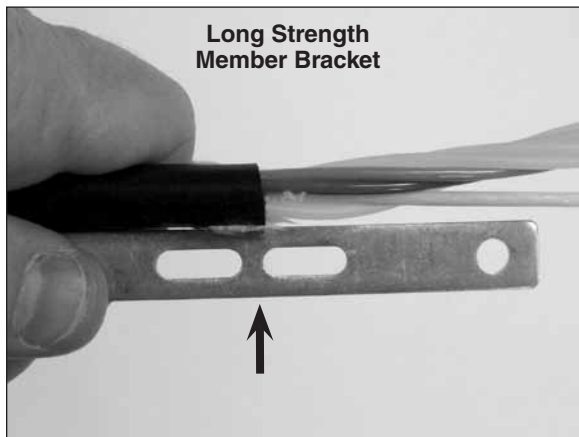
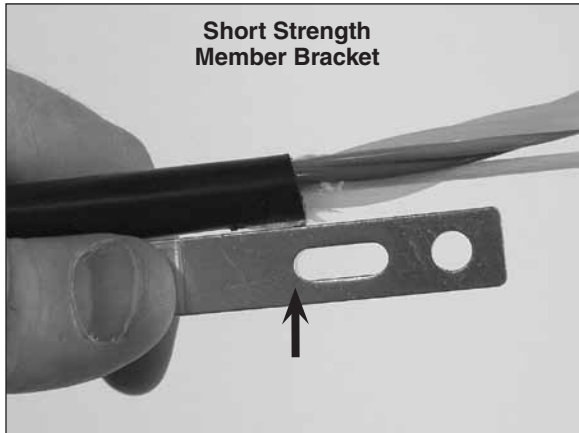

Step #15 Trim strength member(s) flush with end of the strength member bracket(s).

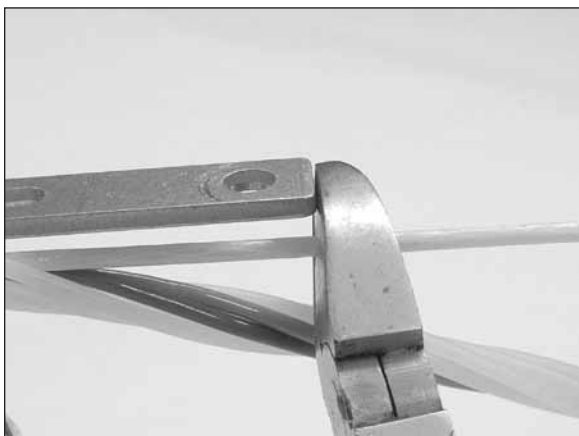

Step #16 Install cap on strength member bracket.

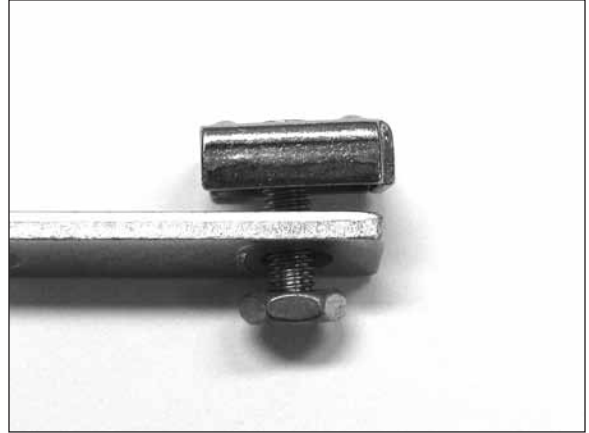

Step #17 Position strength member under cap of strength member bracket.



Step #18 If the cable contains Kevlar®, wrap the braided Kevlar around the stud of the cap as shown.

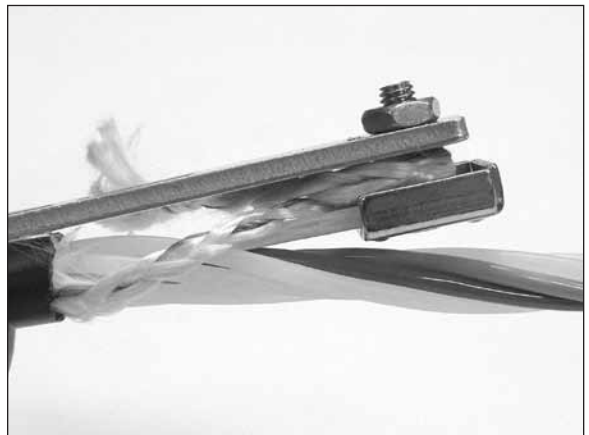

Step #19 Tighten nut of cap to secure strength member and braid under the cap.

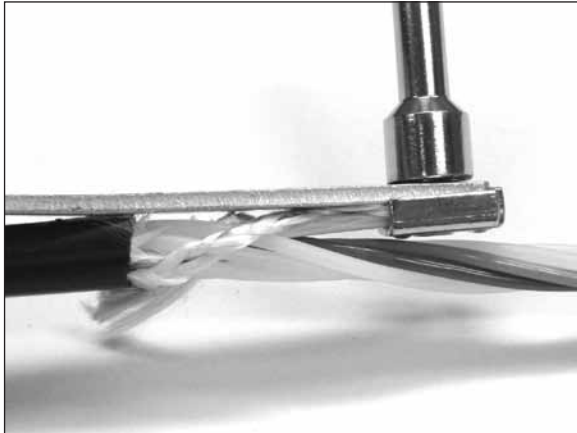

Step #20 Secure cable to strength member bracket with hose clamp.

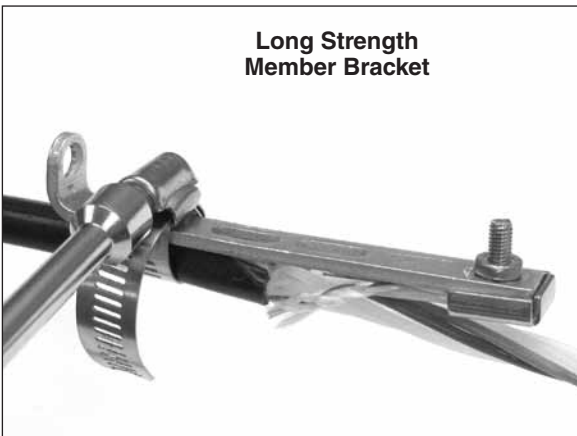

Installing Strength Member Adapter for Large Cable Strength Members

Step #21 For large cable strength members, assemble the adapter to the long strength member bracket as shown.

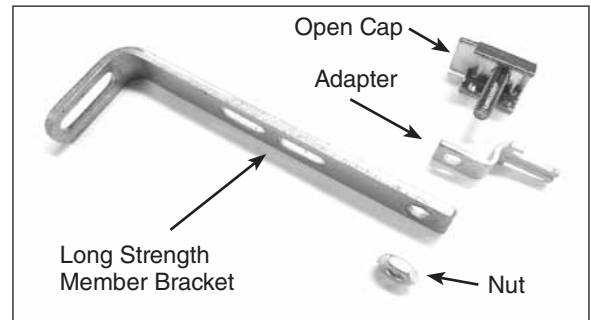

Step #22 Secure large cable strength member(s) to adapter with small hose clamp.

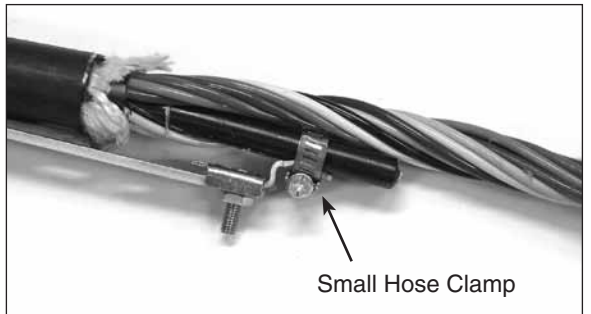

Step #23 If the cable contains Kevlar®, wrap the braided Kevlar around the stud of the cap as shown.

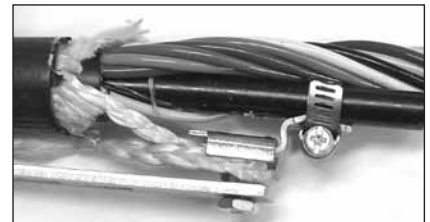

Step #24 Tighten nut of cap to secure under the cap.

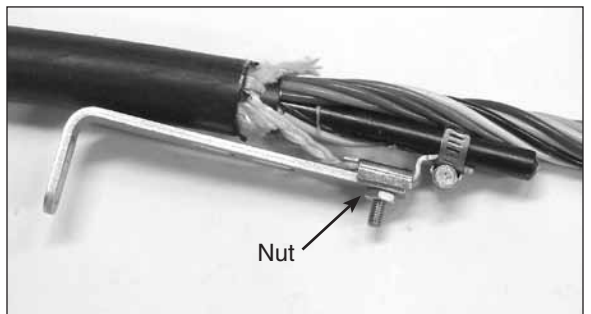

Step #25 Secure cable sheath with hose clamp.

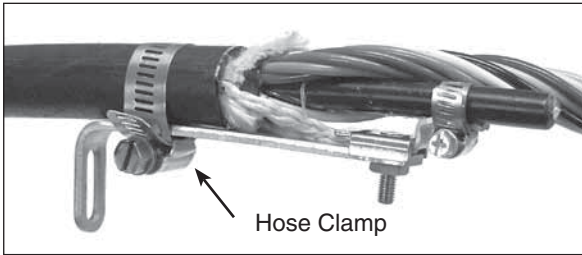

Attaching Shielded Cable to Strength Member Bracket

Step #26 For shielded cable applications, PLP recommends using a 3M 4460-D/FO Fiber Optic Shield Connector (PN: 80803989). Install shield connector on cable and insert stud of shield connector through slot of strength member bracket.

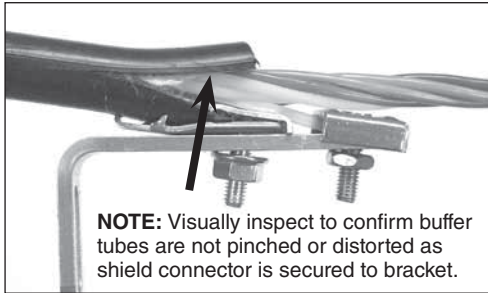

Follow standard company practices when applying shield connector to cable.

Step #27 Secure shield connector to strength member bracket with nut and secure cable strength member under cap of the strength member bracket.

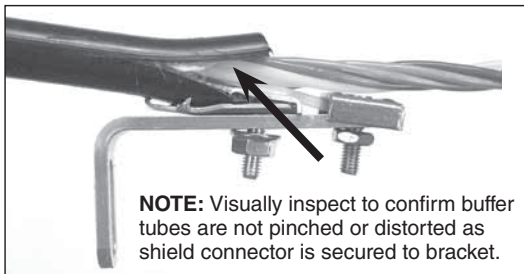

Step #28 Secure shielded cable to strength member bracket with hose clamp.

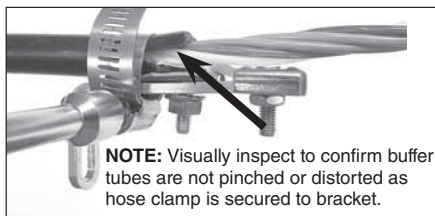

Step #29 Lubricate the outer surface of the grommets.

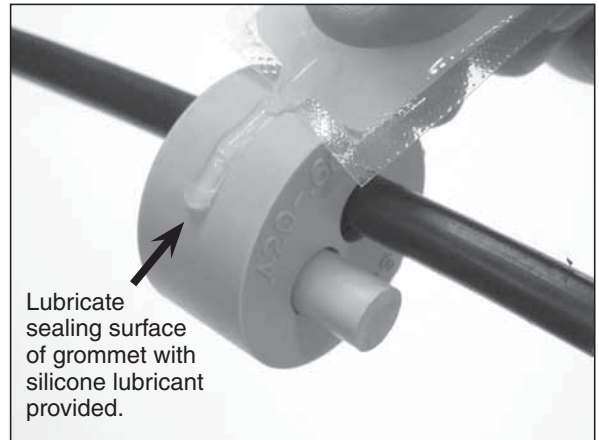

Step #30 Position grommets in end plate slots.

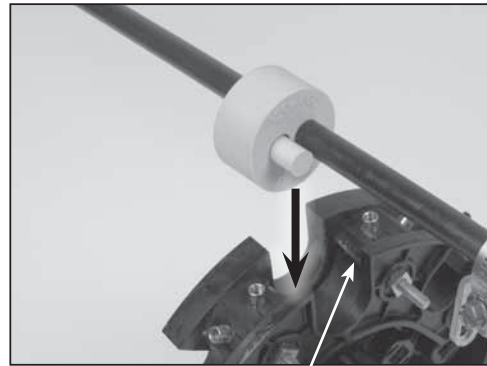

Step #31 Position slot of strength member bracket leg over stud and pull back cable.

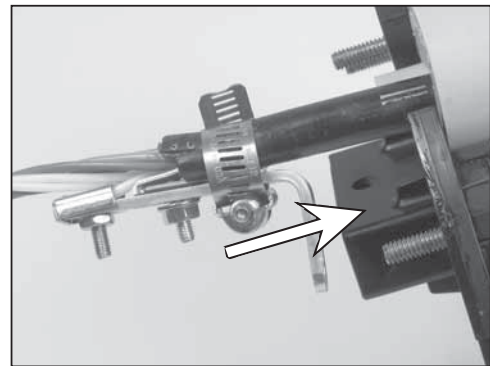

Step #32 Install strength member bracket on stud. Install lock washer and nut against the bracket, but do not tighten fully, so the bracket can slide as the grommet is inserted.

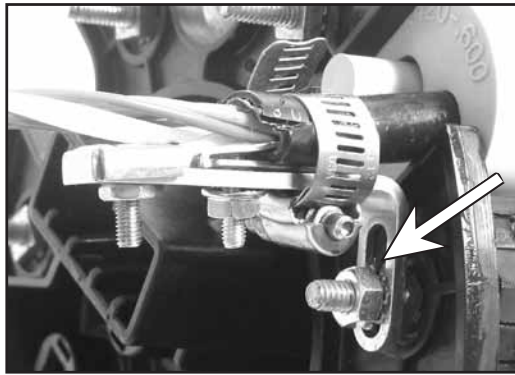

Lock Washer & Nut

Step #35 Complete end plate assembly.

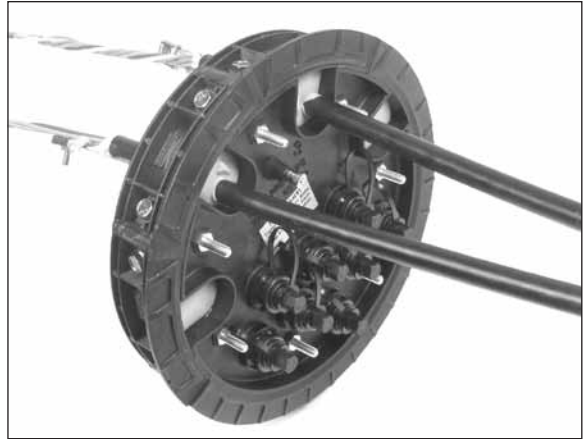

Step #33 Install grommets with plugs in any unused cable port.

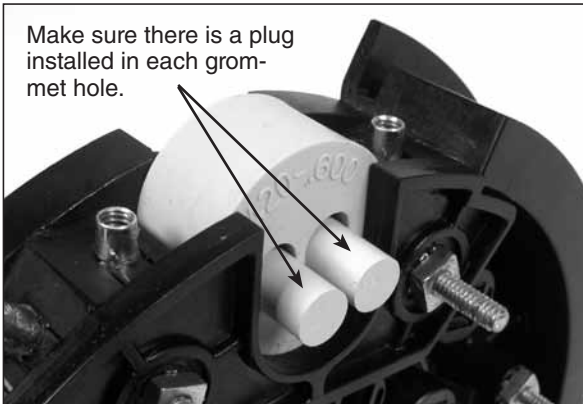

Make sure there is a plug installed in each grommet hole.

Step #36 Re-install end plate onto organizer assembly and secure with bolt.

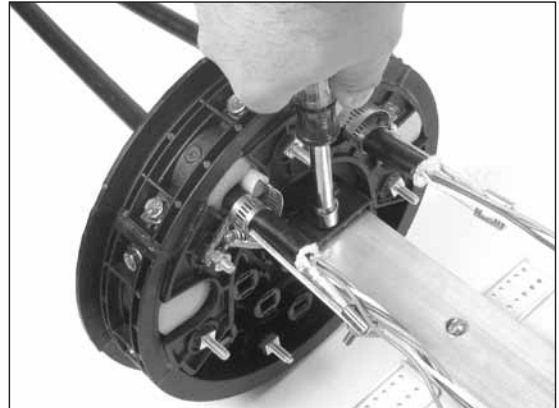

Step #34 Install cable caps and secure with hex bolts. Fully tighten nut against the strength member bracket.



NOTE: Tighten bolts by hand evenly until cable cap is fully seated (DO NOT USE POWER TOOLS TO TIGHTEN BOLTS).

When using a can wrench or nut driver, the installed torque is 35 to 40 in. lbs.

NOTE: TIGHTEN ALL CABLE CAPS.

IMPORTANT: TIGHTEN THE STRENGTH MEMBER AFTER THE CAPS ARE TIGHTENED.

Buffer Tube Applications

Step #37 Route and store buffer tubes in storage brackets. If routing in side storage brackets, see Step #38 for installation of retainer clips.

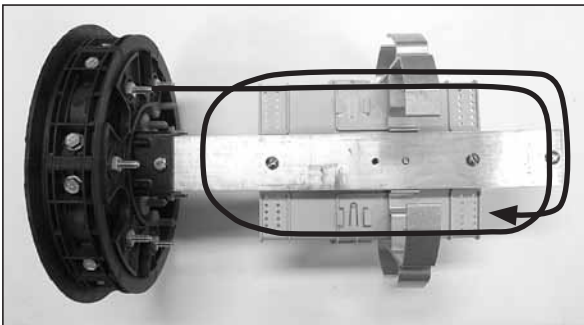
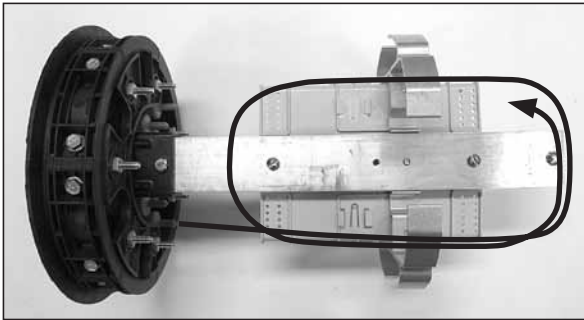

Step #38 To install retainer clip, position the bottom slot of the retainer clip onto the bottom of the bracket. Tilt retainer clip forward until the top of the bracket snaps into the top slot of the retainer clip.

Before



After



Step #39 Route buffer tube(s) to splice tray(s) and secure.

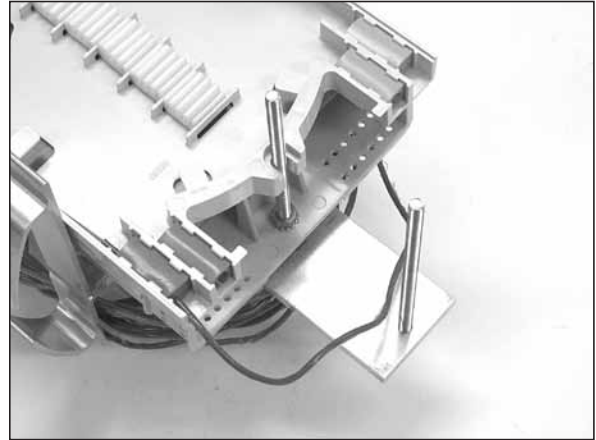

Unitube/Ribbon Applications

Step #40 Route and secure central tube of unitube cables to transition tray.

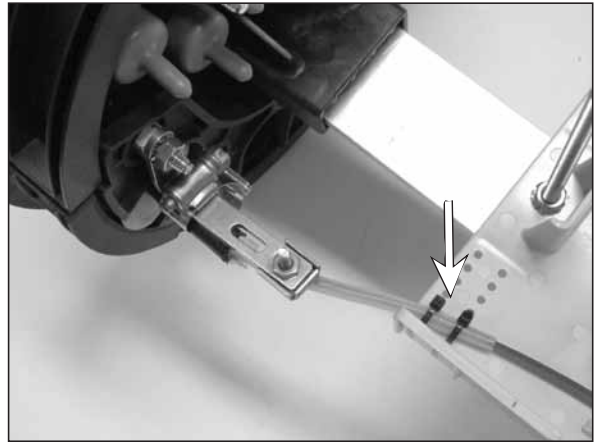

Step #41 Route feeder fibers or ribbons within transition tray.

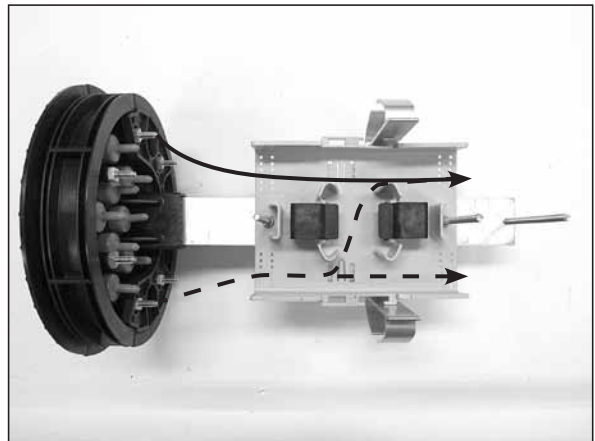

Step #42 Install organizer clips in transition tray and route expressed fibers or ribbons under clips.

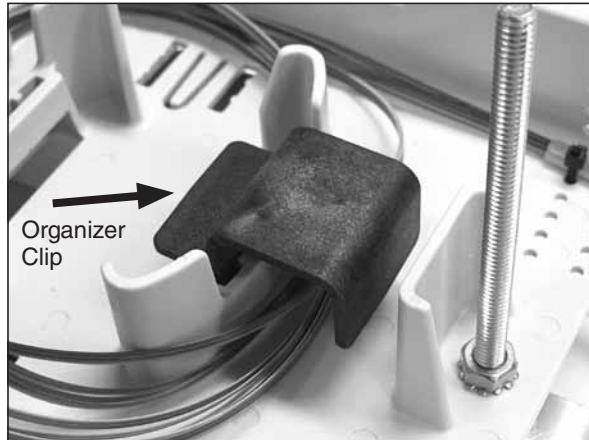

Step #43 Insert fibers or ribbons to be routed to splice tray(s) into transport tube(s) and secure tubes to transition tray.

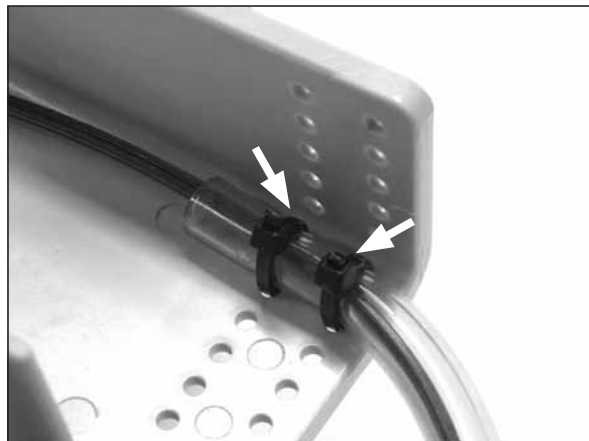

Step #44 Install cover on transition tray.

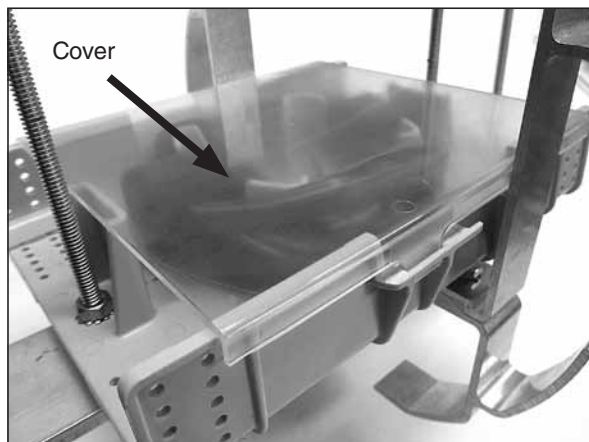

Step #45 Route transport tube(s) to splice tray(s) and secure.

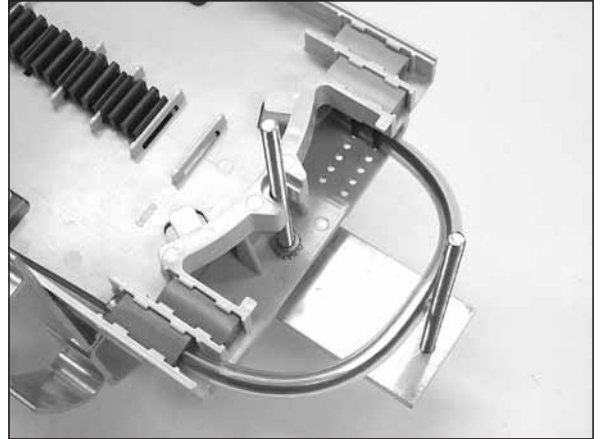

Pigtail Assembly Installations

Step #46 Measure and mark pigtail. Remove the pigtail jacket and Kevlar® beyond this mark.

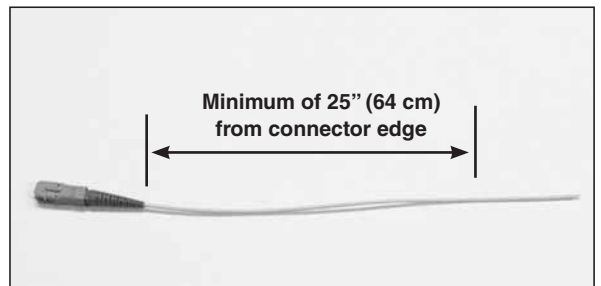

Step #47 Install pigtails into LITE-GRIP® Sleeve.

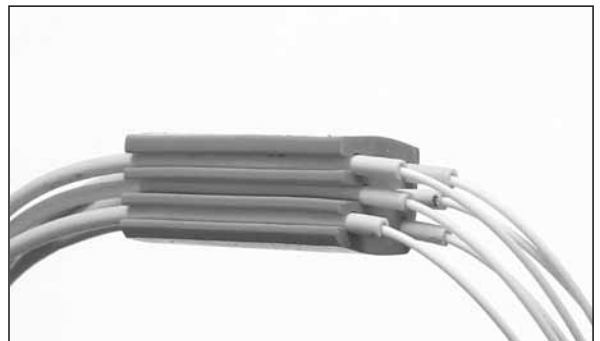

Step #48 Install LITE-GRIP® Sleeve with pigtails into splice tray.

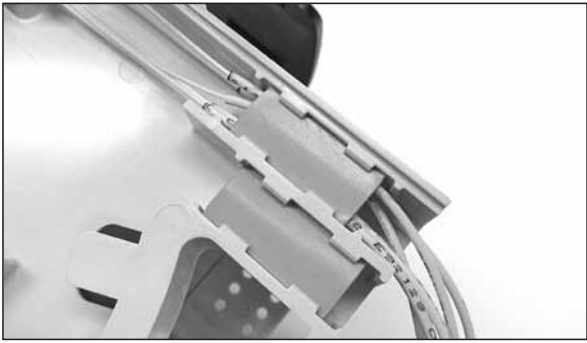

Splice Tray Management

Step #49 Route incoming fibers in splice tray.

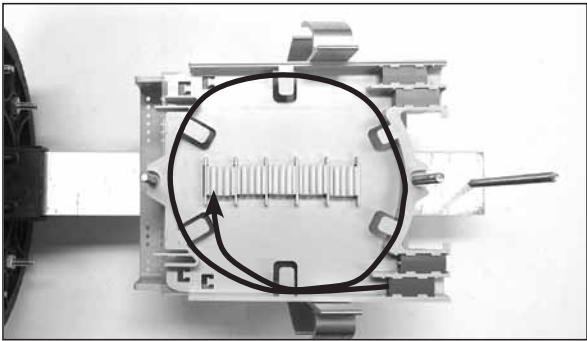

Step #50 Route outgoing pigtail fibers in splice tray.

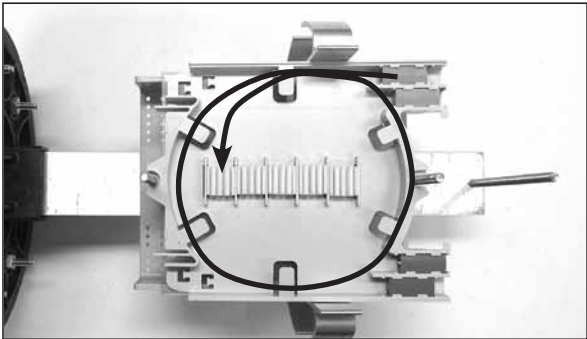

Step #51 Splice incoming fibers to outgoing pigtail fibers per your accepted company practices.

Step #52 Secure splice tray(s) with hold down strap.

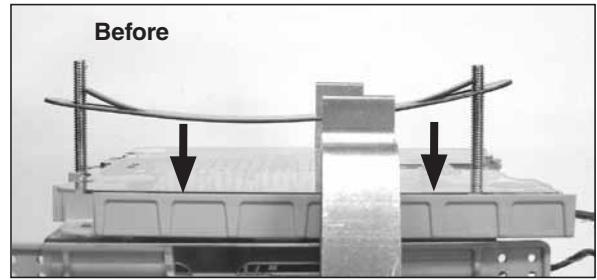

Pigtail Routing

Step #53 Route pigtails to end plate as shown.

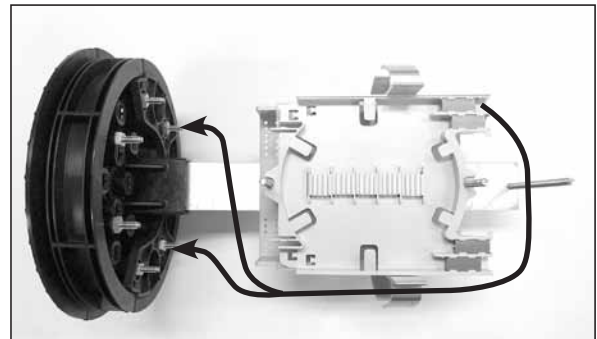

Step #54 Install pigtail connectors into adapters.



Dome Preparation & Installation

Step #55 Lubricate all surfaces around gasket with silicone lubricant to assure easy assembly and closure re-entry.

Lubricate all inner surfaces of the gasket.

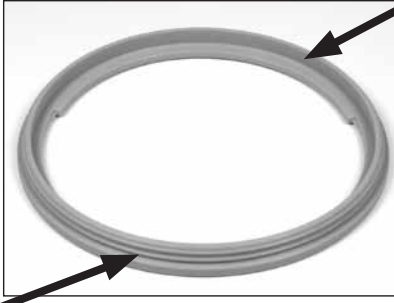

Lubricate all outer surfaces of the gasket.

Step #56 Slide the gasket onto the end plate and press into groove. Make sure to orientate the gasket so that the wide inner flange area of the gasket is seated in the groove of the end plate in the section shown below.

Make sure gasket is seated in groove of end plate.

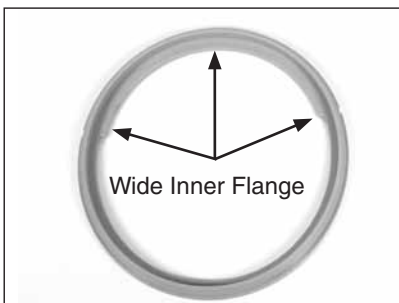

Place the wide inner flange of the gasket in this section of the end plate.



Step #57 Make sure to align the notches of the gasket as shown below.

Align notch of gasket with this seam.

Align notch of gasket with this seam.

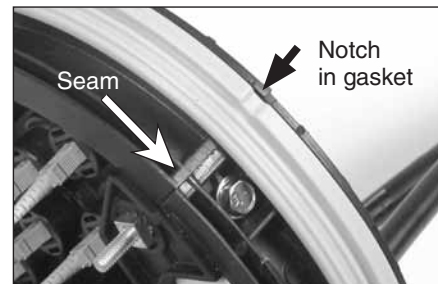
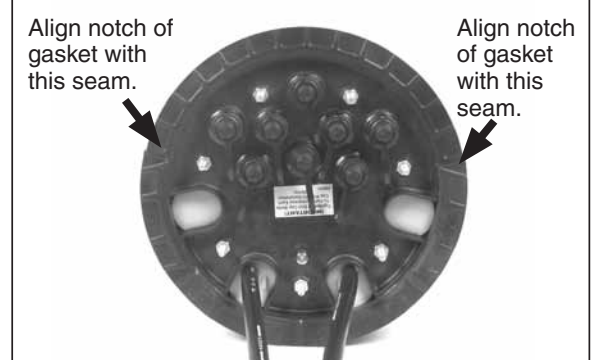

Step #58 Re-tighten all cable cap bolts (Step #34) to ensure that the cable caps are fully seated. When using a can wrench or nut driver, the installed torque is 35 to 40 in. lbs.

Step #59 Position dome over end plate.



Step #60a Install dome collar.

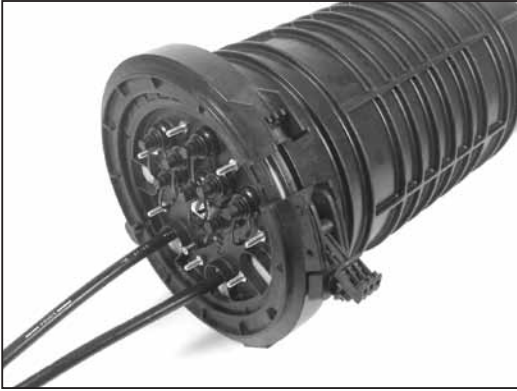

Step #60b Make sure lip of dome is captured underneath the collar before securing the latch.

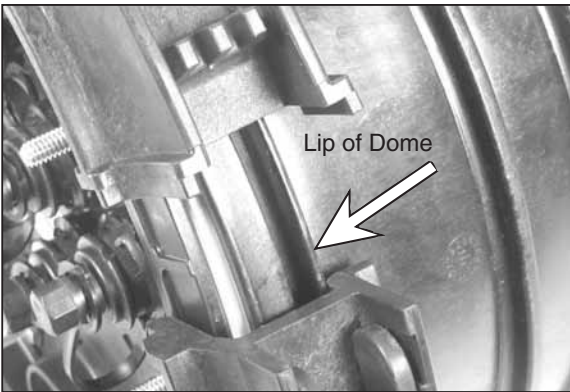

Step #61 Lock collar by twisting the latch fastener clockwise 90 degrees.

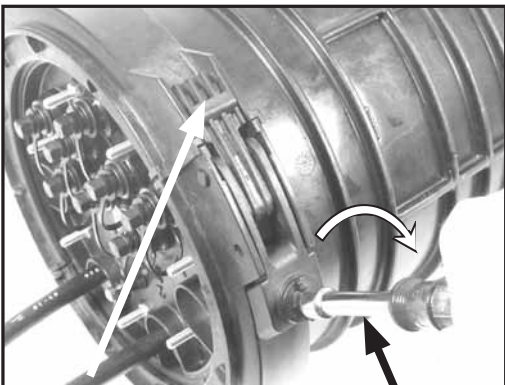

CAUTION: Do not fasten latch until collar is completely installed in the correct position or damage to latch may occur.

Latch Fastener

Step #62 Install drop cable connectors into adapters.

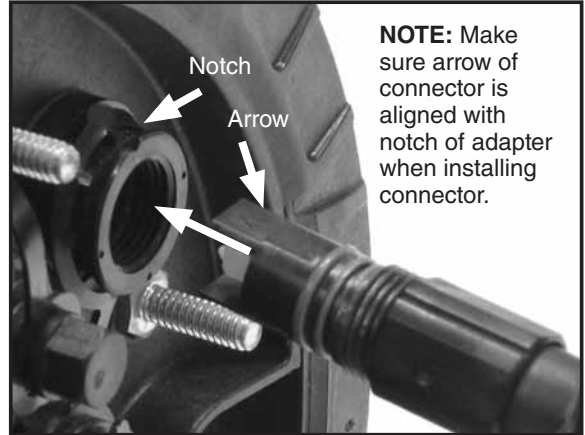

NOTE: Make sure arrow of connector is aligned with notch of adapter when installing connector.

Flash Test Procedure

Step #63 Remove cap from air valve of end plate.

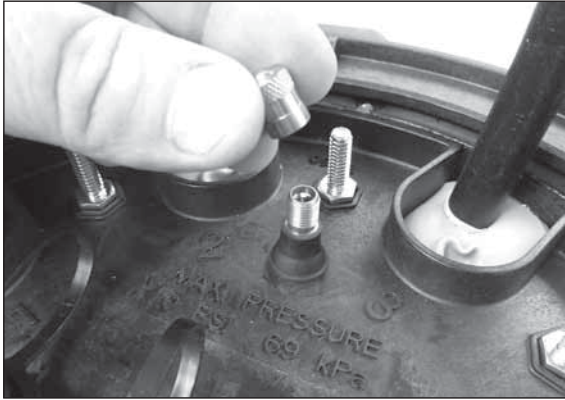

Step #64 Pressurize closure up to a max of 10psi.

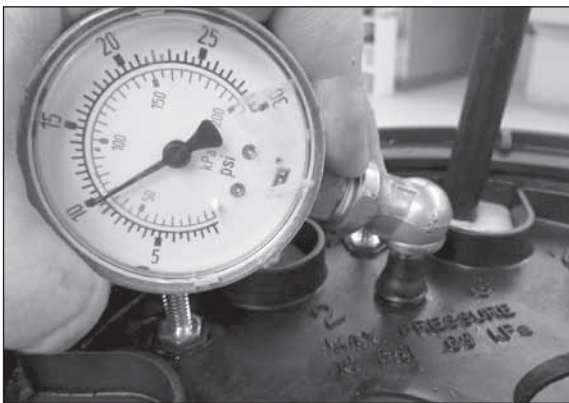

Step #65a Spray all sealing surfaces of the dome end plate with soapy water to determine if there are any leaks.

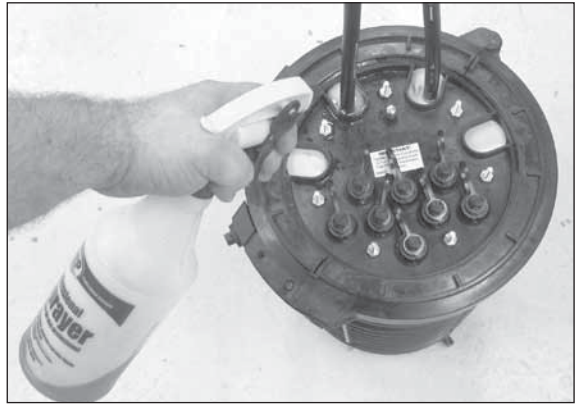

Step #65b For Terminal Dome Closures, make sure to spray and check for leaks around the O-Rings of the hardened adapters.

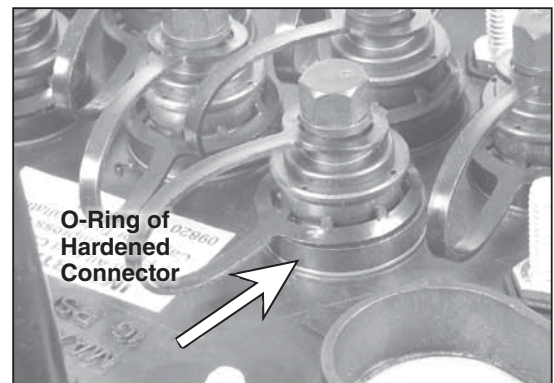

Step #66 Release the pressure in the closure using the bump on the top of the air valve cap.

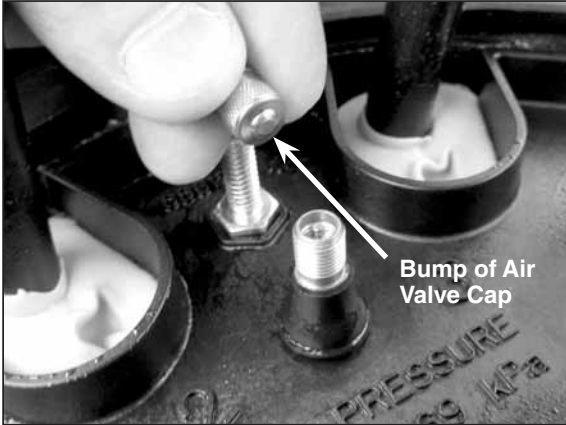

Troubleshooting End Plate Leaks

Leak occurring at the corner of the cable port due to the cap of the cable port not being fully tightened.

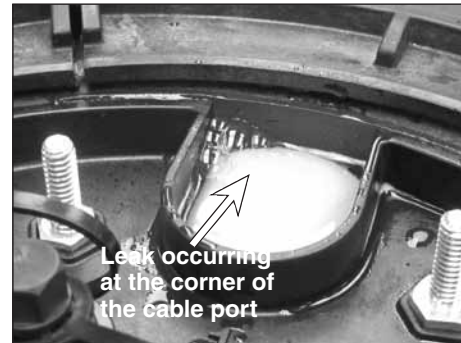

To resolve, remove collar, remove End Plate/Organizer Assembly from the Dome, and tighten bolts on end cap where leak occurred. Reassemble and flash test to confirm that the leak has stopped.

Leak occurring at the cable entry of the grommet due to the cable not being within the stated cable diameter range of the grommet.



To resolve, remove collar, and remove End Plate/Organizer Assembly from the Dome. Remove end cap where leak occurred, remove grommet, remeasure cable with measure tape provided and select proper grommet. Reassemble the components and flash test the closure to confirm that the leak has stopped.

Optional Hardware for Mounting

Step #67 9.5" (292 mm) Dome Aerial Mounting Bracket – End Plate Mount – for ADSS Applications. The COYOTE® 9.5" Dome Aerial Mounting Bracket Kit (Cat. No. 8003941) can be used to suspend the COYOTE 9.5" x 19" (292 mm x 509 mm) or 9.5" x 28" (292 mm x 749) Dome Closure from ADSS cable. To install the aerial mounting bracket, first secure the gusset bracket to the hanger bracket before attaching both to the studs of dome end plate. Next, attach the dome bracket to the mounting tabs of the dome. Lastly, attach a hanger strap bracket to the dome bracket and one to the back side of the hanger bracket before mounting the dome closure to the dead-end using the ADSS clamps of the hanger strap brackets.

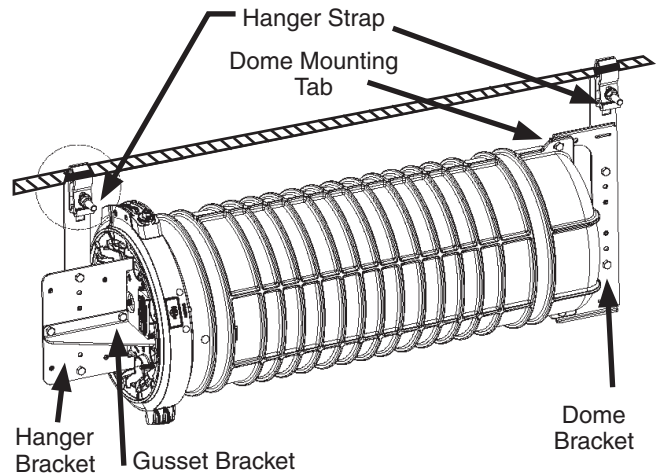

Step #68 9.5" (292 mm) Dome Aerial Mounting Bracket – Dome Mount Applications. The COYOTE 9.5" Dome Mount Aerial Bracket Kit (Cat. No. 8003940) can be used to suspend the COYOTE 9.5" x 19" (292 mm x 509 mm) or 9.5" x 28" (292 mm x 749) Dome Closure from messenger wire. To install the dome mount aerial brackets, position the brackets in the banding channels of the dome and insert banding (plastic or metal) through the slots of the brackets. Tighten the banding until the brackets are secure before mounting the closure to the messenger wire with the bug nuts of the brackets.

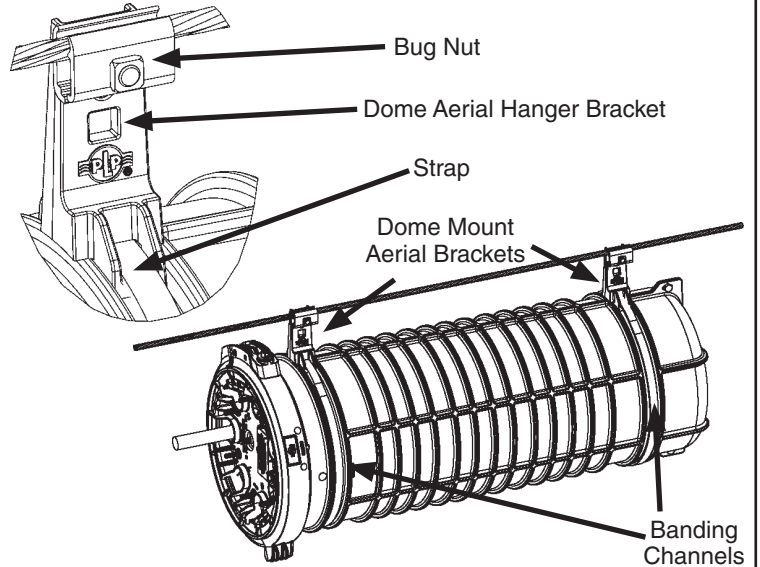

Step #69 9.5" (292 mm) Dome Aerial Mounting Bracket – for ADSS Applications. The COYOTE 9.5" Dome Mount Aerial Bracket Kit for ADSS (Cat. No. 8003869) can be used to suspend the COYOTE 9.5" x 19" (292 mm x 509 mm) or 9.5" x 28" (292 mm x 749) Dome Closure from ADSS cable. To install the Dome Mount Aerial Brackets, position the brackets in the banding channels of the dome and insert banding (plastic or metal) through the slots of the brackets. Tighten the banding until the brackets are secure before mounting the closure to the dead-end with the ADSS clamp.

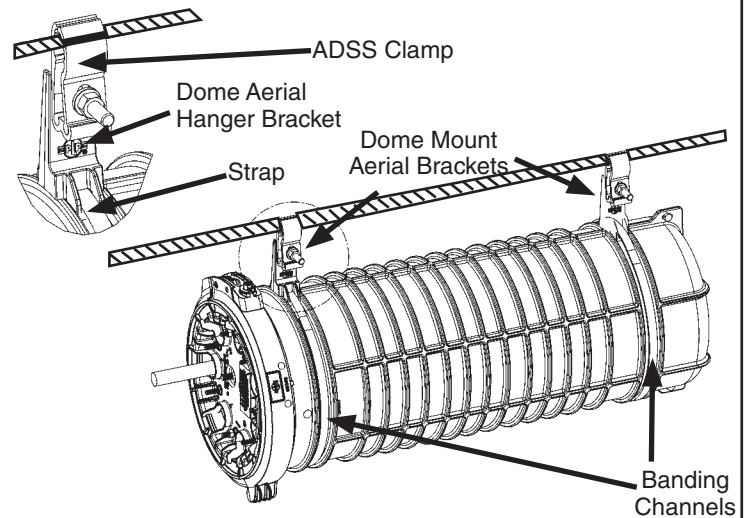

Step #70 **9.5" x 28" (292 mm x 749 mm) Dome Pole Mounting Bracket.** The COYOTE 9.5" Dome Pole Mounting Bracket Kit (Cat. No. 8003942) can be used to secure the COYOTE 9.5" x 19" (292 mm x 509 mm) or 9.5" x 28" (292 mm x 749 mm) Dome Closure to wood, concrete, or steel poles. To install the pole mounting bracket, first secure the gusset bracket to the hanger bracket before attaching both to the studs of dome end plate.

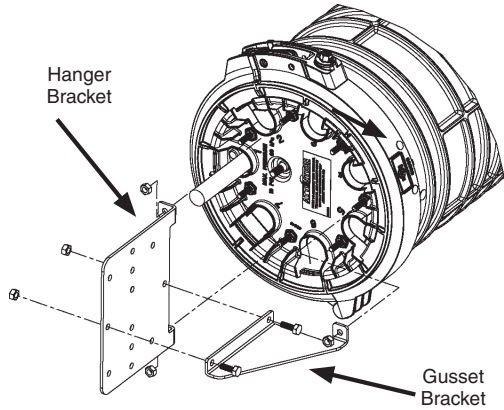

Step #71 Attach the hanger bracket to the pole mounting plate with the gusset side facing the same side as the bolt hole tabs of the pole mounting bracket.

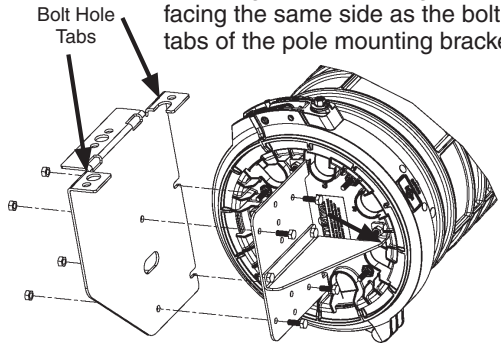

Step #72 Attach the dome pole mounting plate to the pole with either 5/8" (M16) through bolts, 1/4" (6.35 mm) lag screws, or metal banding.

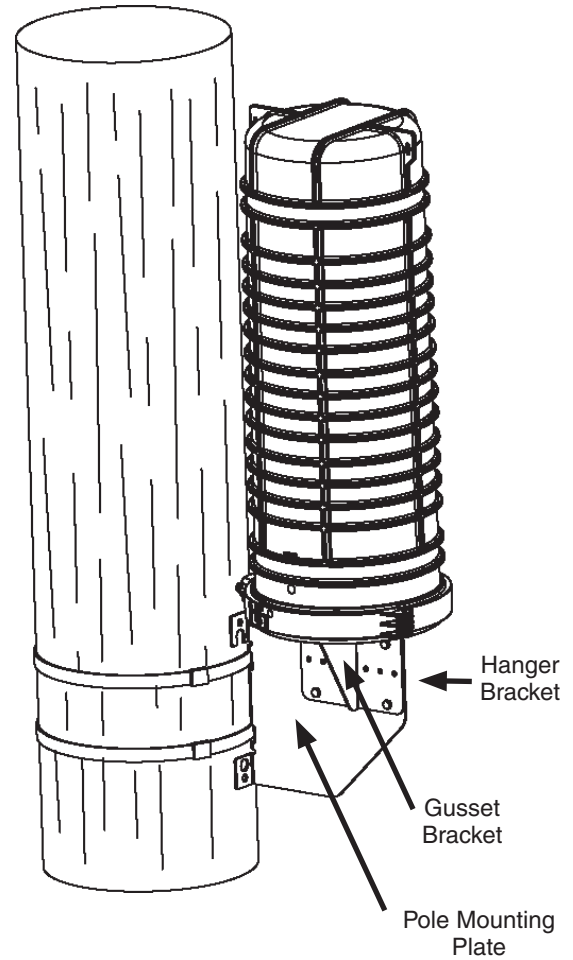

SAFETY CONSIDERATIONS

This application procedure is not intended to supersede any company construction or safety standards. This procedure is offered only to illustrate safe application for the individual. **FAILURE TO FOLLOW THESE PROCEDURES MAY RESULT IN PERSONAL INJURY OR DEATH.**

Do not modify this product under any circumstances.

This product is intended for use by trained technicians only. **This product should not be used by anyone who is not familiar with, and not trained to use it.**

When working in the area of energized lines, extra care should be taken to prevent accidental electrical contact.

For proper performance and personal safety, be sure to select the proper size PREFORMED™ product before application.

PREFORMED products are precision devices. To insure proper performance, they should be stored in cartons under cover and handled carefully.



PREFORMED LINE PRODUCTS

P.O. Box 91129, Cleveland, Ohio 44101 • 440.461.5200 • www.preformed.com • e-mail: inquiries@preformed.com

SP3107-1