

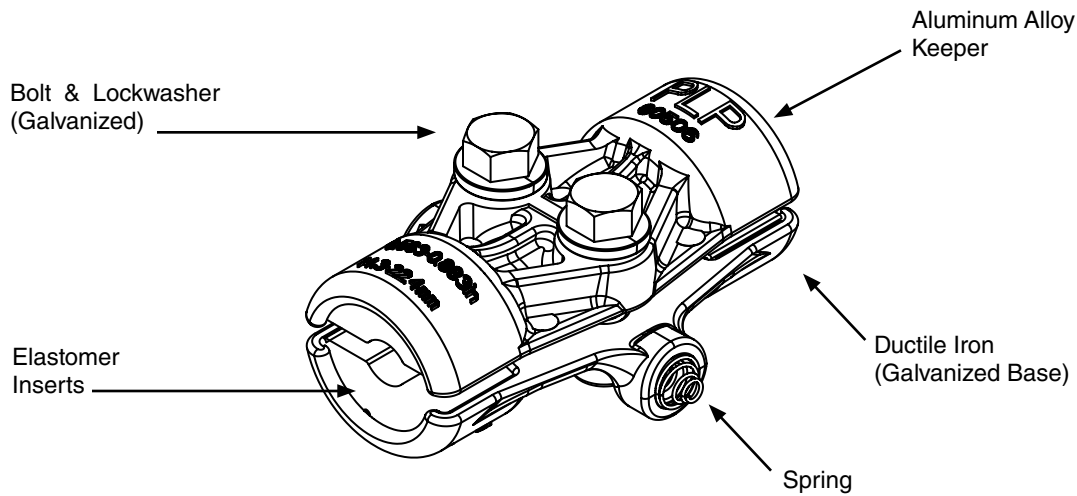

CUSHION-GRIP® Support

NOMENCLATURE



GENERAL RECOMMENDATIONS

The CUSHION-GRIP Support is intended for use on all aluminum based conductors, and is designed to reduce the static and dynamic stresses at the support point, so that the conductor is protected against the effects of oscillations. The conductor is cushioned by field proven, integral elastomer inserts, which guard against abrasion, wear, and fatigue.

The level of protection provided by the CUSHION-GRIP Support is comparable to a bolted clamp over armor rods. This equates to a reduction in bending strain as high as 50% as compared to bare conductor in a bolted clamp. This reduction in bending strain can be directly related to an increase in overall conductor life. The CUSHION-GRIP Support is designed for up to 125°C continuous conductor operation (150°C two hour emergency), and the HT version can be used for applications with continuous conduction operating temperatures up to 200°C (225°C two hour emergency).

Thermal Rating (Continuous)
Standard 125°C
HT Version 200°C

Features and Benefits:

- The CUSHION-GRIP Support is shipped assembled. All fasteners are captivated in the keeper.
- Labor Savings – To install the CUSHION-GRIP Support simply install the base, place the keeper over the conductor, and tighten bolts.
- Integral Cushions – minimize conductor bending stresses at critical entry locations.

VERTICAL ULTIMATE LOAD. The CUSHION-GRIP Support will withstand a pulloff load from the trunnion pins of the insulator cap of 5,000 lbs., applied in any direction. This includes the vertical up direction (uplift).

SLIP LOAD. When initially installed, the CGS has a slip load that ranges between 10% to 15% of the conductor's rated breaking strength (RBS).

LINE ANGLE. The maximum recommended line angle for a CUSHION-GRIP Support is 30°.

CUSHION-GRIP® Support

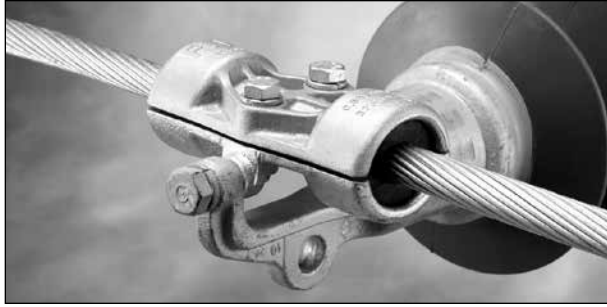

ORDERING INFORMATION

Catalog Number	Conductor Range (mm)		Nominal Conductor Sizes	Weight/Unit Pounds (Kg)	Standard Carton Quantity
	Min.	Max.			
CGS-2100	.312" (7.9)	.608" (15.4)	#2 to 226 Kcmil	1.45 (0.66)	3
CGS-2101	.609" (15.4)	.883" (22.4)	226 Kcmil to 477 Kcmil	2.40 (1.1)	3
CGS-2102	.884" (22.4)	1.196" (30.4)	556 Kcmil to 954 Kcmil	3.50 (1.6)	3
CGS-2103	1.197" (30.4)	1.504" (38.2)	954 Kcmil to 1590 Kcmil	5.00 (2.3)	3

Note: For high temperature (HT) version add "HT" to the catalog number (Example: CGS-2102HT).

DIMENSIONAL INFORMATION

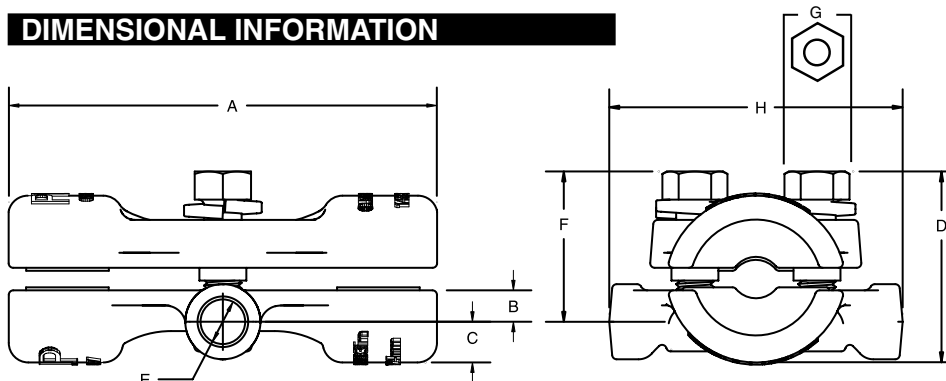

Catalog Number	Dimensions (m)							
	A	B	C	D	E	F	G	H
CGS-2100	5.3	0.34	0.42	2.1	0.595	1.7	9/16	3-7/8
CGS-2101	6.7	0.42	0.51	2.6	0.595	2	3/4	3-7/8
CGS-2102	6.9	0.70	0.34	2.9	0.595	2.6	3/4	3-7/8
CGS-2103	6.5	0.75	0.88	3.4	0.595	2.4	3/4	3-7/8

CLAMP TOP TRUNNION

To insure proper fit and service life, it is recommended that only line post insulators with clamp top trunnion caps that conform to ANSI standards be used. See the illustration on the right for nominal cap dimensions that illustrate ANSI standards that have been established outlining the permissible dimensions and tolerances for trunnion caps. Consult the insulator manufacturer when in doubt about insulator standards.

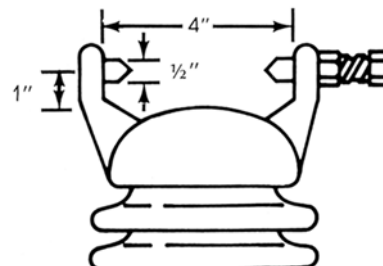

The above dimensions are approximates for design information. Consult ANSI specification C29.7-1977 for exact dimensions.